

Table of Contents

- WIZ550web Datasheet 1
- Overview 1
- Hardware Specification 1
 - WIZ550web 1
 - WIZ550web Baseboard 3
- AC/DC Characteristics 6
 - WIZ550WEB 6
- Reference Schematic & Parts 6
 - Schematic 6
 - Parts Datasheet 6
- Dimension 7
 - WIZ550web 7
 - WIZ550web Baseboard 7

www.signal.com.tr

www.signal.com.tr

WIZ550web Datasheet

Overview

This page provides information about the hardware of WIZ550web and its Baseboard as following:

- Basic Hardware Specification
- Operating Characteristics & I/O Characteristics
- Reference Schematics
- Dimension information

The revision history will be updated in this page in case of any changes of hardware specification or exterior design.

2014/10/28 13:16 · jeongsuk

Hardware Specification

WIZ550web

- MCU : **STM32F103RBT6**
- TCP/IP Controller : **W5500**
- RJ45 (Integrated Transformer) : **J1B1211CCD**
- External Flash Memory : **AT45DB081D**
- 2.54mm Pin Header x 2



J1.pin	MCU.pin	all MCU pin functions (alternative / remap)	Module.pin	MCU.pin	all MCU pin functions (alternative / remap)	J2.pin
		STM32F103RBT6 = LQFP64			STM32F103RBT6 = LQFP64	
1	37	PC6, (TIM3-CH1)	D0	3V3D	--	1
2	38	PC7, (TIM3-CH2)	D1	3V3D	--	2
3	39	PC8, (TIM3-CH3)	D2	3V3A	--	3
4	40	PC9, (TIM3-CH4)	D3	VBAT	--	4
5	41	PA8, USART1-CK, (TIM1-CH1), MCO	D4	A0	23 PA7, (SPI1-MOSI), ADC12-IN7, (TIM3-CH2, TIM1-CH1N)	5
6	50	PA15, JTDI, (TIM2-CH1-ETR, SPI1-NSS)	D5	A1	22 PA6, (SPI1-MISO), ADC12-IN6, (TIM3-CH1, TIM1-BKIN)	6
7	51	PC10, (USART3-TX)	D6	A2	21 PA5, (SPI1-SCK), ADC12-IN5	7
8	52	PC11, (USART3-RX)	D7	A3	20 PA4, (SPI1-NSS, USART2-CK), ADC12-IN4	8
9	53	PC12, (USART3-CK)	D8	UART2_RX	17 PA3, (USART2-RX), ADC12-IN3, (TIM2-CH4)	9
10	54	PD2, TIM3-ETR	D9	UART2_TX	16 PA2, (USART2-TX), ADC12-IN2, (TIM2-CH3)	10
11	55	PB3, JTDI, (TracesWO, TIM2-CH2, SPI1-SCK)	D10	UART2_RTS	15 PA1, (USART2-RTS), ADC12-IN1, (TIM2-CH2)	11
12	56	PB4, JNTRST, (TIM3-CH1, SPI1-MISO)	D11	UART2_CTS	14 PA0, WKUP, (USART2-CTS), ADC12-IN0, (TIM2-CH1-ETR)	12
13	57	PB5, I2C1-SMBAL, (TIM3-CH2, SPI1-MOSI)	D12	UART1_RX	43 PA10, (USART1-RX, TIM1-CH3)	13
14	58	PB6, (I2C1-SCL, TIM4-CH1, USART1-TX)	D13	UART1_TX	42 PA9, (USART1-TX, TIM1-CH2)	14
15	59	PB7, (I2C1-SDA, TIM4-CH2, USART1-RX)	D14	UART1_RTS	45 PA12, (USART1-RTS, (CAN-TX, TIM1-ETR), USB-DP)	15
16	61	PB8, (TIM4-CH3, I2C1-SCL, CAN-RX)	D15	UART1_CTS	44 PA11, (USART1-CTS, (CAN-RX, TIM1-CH4), USB-DM)	16
17	7	NRST	/RST	GND	--	
18	60	BOOT0	BOOT0	GND	--	
				GNDA	--	

Pin Description

As it is used in the EVB and for the web-server by default

Ref No.	Pin No.	Symbol	Type	Description
J1	1	D0	I/O	Digital 0 I/O
	2	D1	I/O	Digital 1 I/O
	3	D2	I/O	Digital 2 I/O
	4	D3	I/O	Digital 3 I/O
	5	D4	I/O	Digital 4 I/O
	6	D5	I/O	Digital 5 I/O
	7	D6	I/O	Digital 6 I/O
	8	D7	I/O	Digital 7 I/O
	9	D8	I/O	Digital 8 I/O / Boot Pin
	10	D9	I/O	Digital 9 I/O
	11	D10	I/O	Digital 10 I/O
	12	D11	I/O	Digital 11 I/O
	13	D12	I/O	Digital 12 I/O
	14	D13	I/O	Digital 13 I/O
	15	D14	I/O	Digital 14 I/O
	16	D15	I/O	Digital 15 I/O
	17	NRST	I	System Reset Input, Active Low
	18	BOOT0	I	BOOT0 Input, Active High

Ref No.	Pin No.	Symbol	Type	Description
J2	1	3V3D	P	Supply DC +3.3V , Digital Power
	2	3V3D	P	Supply DC +3.3V , Digital Power
	3	3V3A	P	Supply DC +3.3V , Analog Power
	4	VBAT	P	Supply DC +3.3V , Low Power Mode
	5	A0	I	Analog 0 Input
	6	A1	I	Analog 1 Input
	7	A2	I	Analog 2 Input
	8	A3	I	Analog 3 Input
	9	UART2_RX	I	Receiver input for UART2
	10	UART2_TX	O	Transmitter output for UART2
	11	UART2_RTS	O	Request To Send output for UART2
	12	UART2_CTS	I	Clear To Send input for UART2
	13	UART1_RX	I	Receiver input for UART1
	14	UART1_TX	O	Transmitter output for UART1
	15	UART1_RTS	O	Request To Send output for UART1
	16	UART1_CTS	I	Clear To Send input for UART1
	17	GND	P	Digital Power Ground
	18	GND	P	Digital Power Ground
	19	GNDA	P	Analog Power Ground

WIZ550web Baseboard

- DC 9~24V Power Input
- Digital Output 8EA (Relay - HR91C-05)
- Digital Input 8EA (Photocouplers - TLP290-4)
- Analog Input 4EA
- RS-232C
- RS-422

Digital Output Port

WIZ550web Baseboard has eight (D0-D7) relay output stage. Below is a photo of basic internal circuit. Jumper, relay NC (Normal close) and NO (Normal Open) can be set.

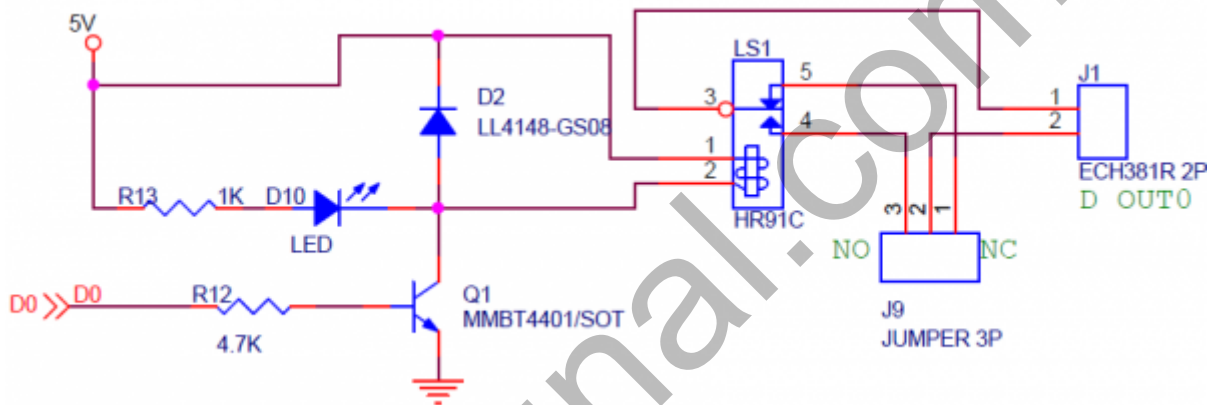

See the table below for State action.

Input value	Relay status value	NC output value	NO output value
0	OFF	Close	Open
1	ON	Open	Close

Output port voltage and current characteristics, see the table below.

NO	5A 28VDC	10A 125VAC	5A 250VAC
NC	3A 28VAC	5A 125VDC	3A 250VDC

Digital Input Port

WIZ550web Baseboard has eight (D8 to D15) Photocoupler via a digital input columns. Below is a photo of basic internal circuit. There is no polarity input, and ON/OFF is distinguished from this potential difference between the two input signals.

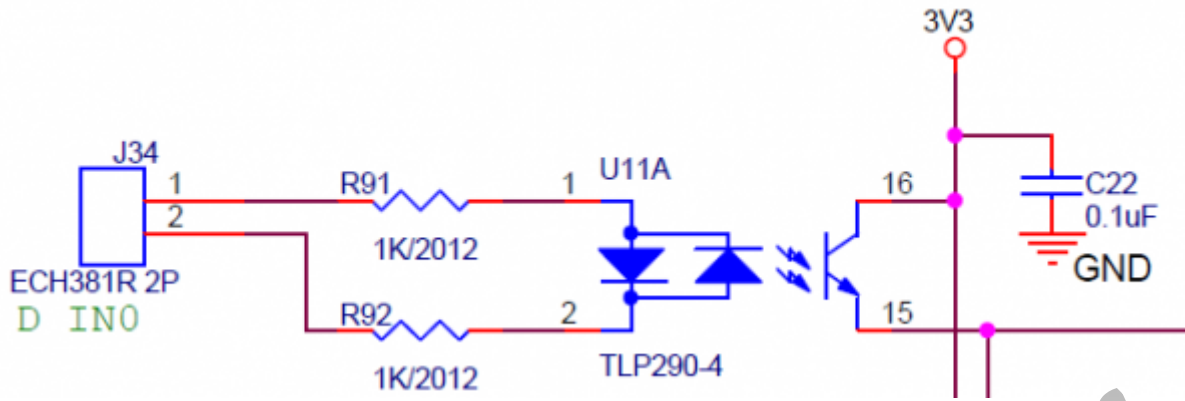

See the table below for the electrical characteristics of the input.

Under 1.4V	Low
Over 2.1V	High
Max Voltage	24V
Potential difference	No. There are two input signals On/Off by potential difference

Four (D8-D11) digital inputs are connected as shown in tact switch inside the Baseboard, and these connections have select Jumper J23-J26.

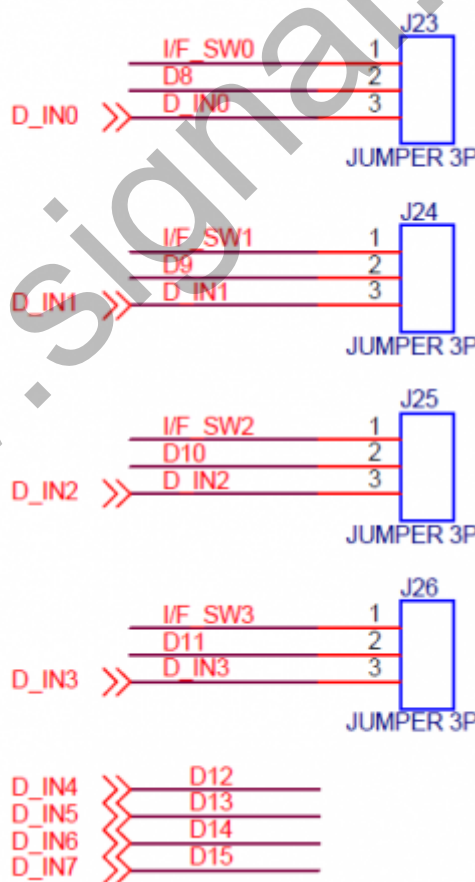

Analog Input Port

WIZ550web Baseboard has four (A0-A3) analog input columns. Below is a photo of basic internal circuit. It is possible to simply enter 0 to 12V and has entered in the WIZ550WEB through the internal

circuitry.

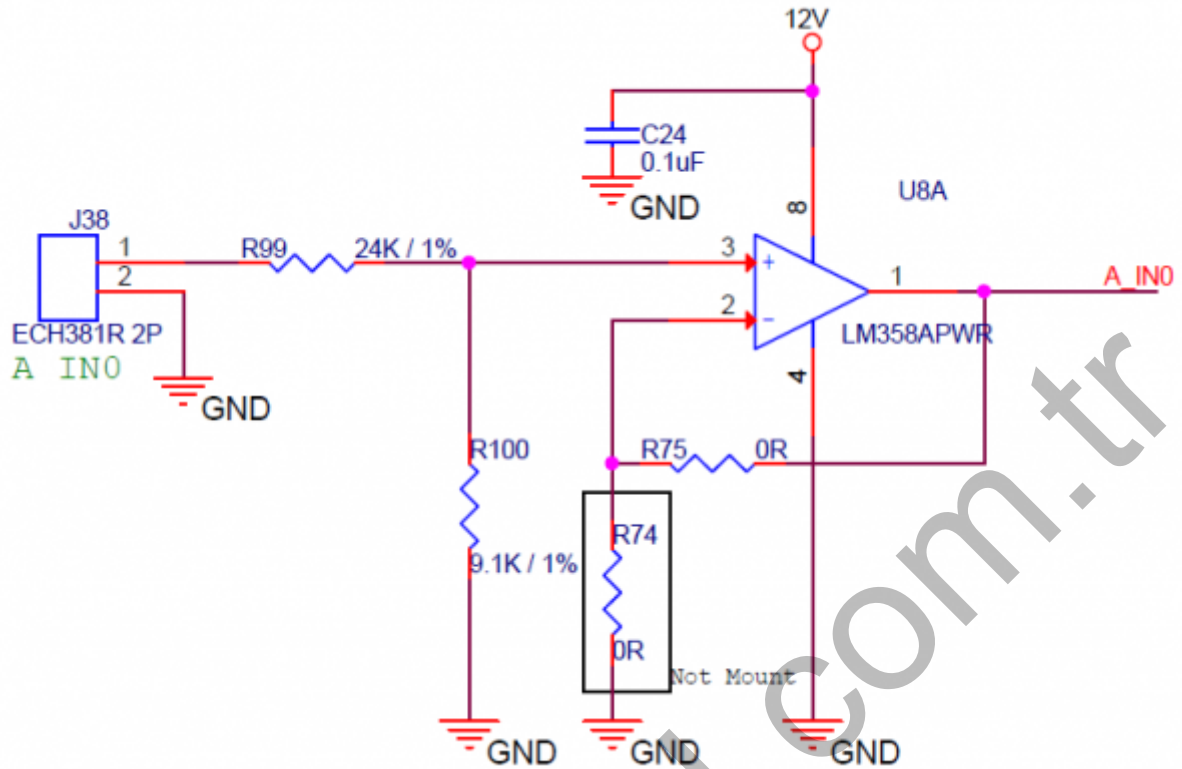

Two of the Analog Input (A0, A1) have connected with a variable resistor (10K) and a temperature sensors (TC1047AVNB) in the Baseboard, this connection can opt to J26, J28 Jumper.

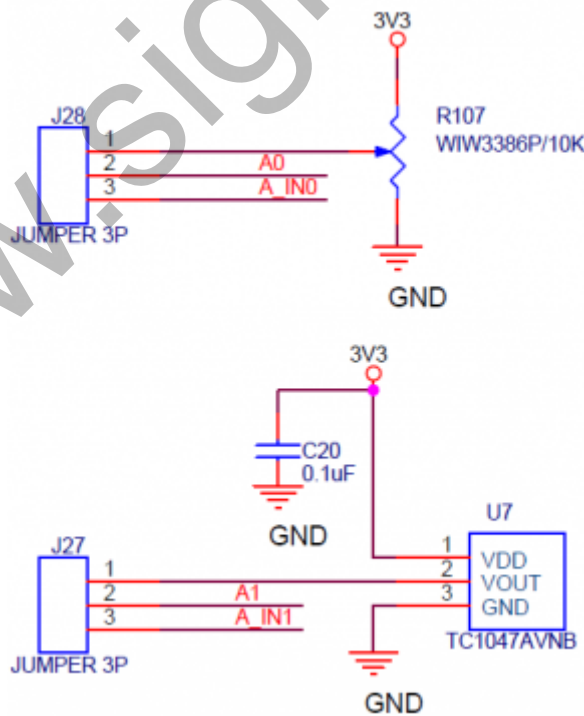

2014/10/28 13:17 · jeongsk

AC/DC Characteristics

WIZ550WEB

General Operating Conditions

Symbol	Parameter	Pins	Min	Typ	Max	Unit
VDD	Standard operating voltage	3V3D	2	3.3	3.6	V
VDDA	Analog operation voltage (ADC not used)	3V3A	2.0	3.3	3.6	V
	Analog operation voltage (ADC used)	3V3A	2.4	3.3	3.6	V
VBAT	Backup operating voltage	VBAT	0.8	3.3	3.6	V
VIN	I/O Digital input voltage	D0~D15	0	-	VDD+0.3	V
	I/O Analog input voltage	A0~A3	0	-	VDD+0.3	V
	BOOT0	BOOT0	0	-	5.5	V
	NRST	NRST	0	-	VDD+0.3	V

I/O Static Characteristic

Symbol	Parameter	Pins	Min	Typ	Max	Unit
VIL	Low level input voltage	D0~D15	-0.5	-	0.7	V
VIH	High level input voltage	D0~D15	2.0	-	VDD	V
VIO	Output current sunk by any I/O and control pin	D0~D15	-	-	25	mA
	Output current source by any I/O and control pin	D0~D15	-	-	-25	mA
VIL(NRST)	NRST Input low level voltage	NRST	-0.5	-	0.8	V
VIH(NRST)	NRST Input high level voltage	NRST	2	-	3.3	V

2014/10/28 13:17 · jeongsk

Reference Schematic & Parts

Schematic

Part	Version	Schematic
WIZ550web	1.0	wiz550web_v100_140925.pdf
WIZ550web Baseboard	1.0	wiz550web-bb_v100_140925.pdf

Parts Datasheet

Parts	Description	Datasheet
STM32F103RBT6	ARM 32-bit Cortex™ -M3 CPU Core	STM32F103RBT6
W5500	WIZnet TCP/IP Chip	W5500
AT45DB081D-SU	8-Megabit Serial Flash Memory	AT45DB081D-SU
J1B1211CCD	Transformer + RJ45 + LED, Industrial	J1B1211CCD
HR91C-05	1 pole, 3-10A Relay, 1c(SPDT)	HR91C-05
SP3485EN	Low Power Half-Duplex RS-485 Transceivers	SP3485EN
SP3232EBEY	True +3.0V to +5.5V RS-232 Transceivers	SP3232EBEY

Parts	Description	Datasheet
TC1047AVNB	Temperature to Voltage Sensor	TC1047AVNB
LM358APWR	Dual Operational Amplifiers	LM358APWR
TLP290-4	4-Channel Transistor-Output Photocouplers	TLP290-4
AOZ1210AI	EZBuck 2A Simple Buck Regulator	AOZ1210AI

2014/10/28 13:17 · [jeongsk](#)

Dimension

WIZ550web

74.4mm(W) x 30mm(L) x 24mm(H) (±0.5)

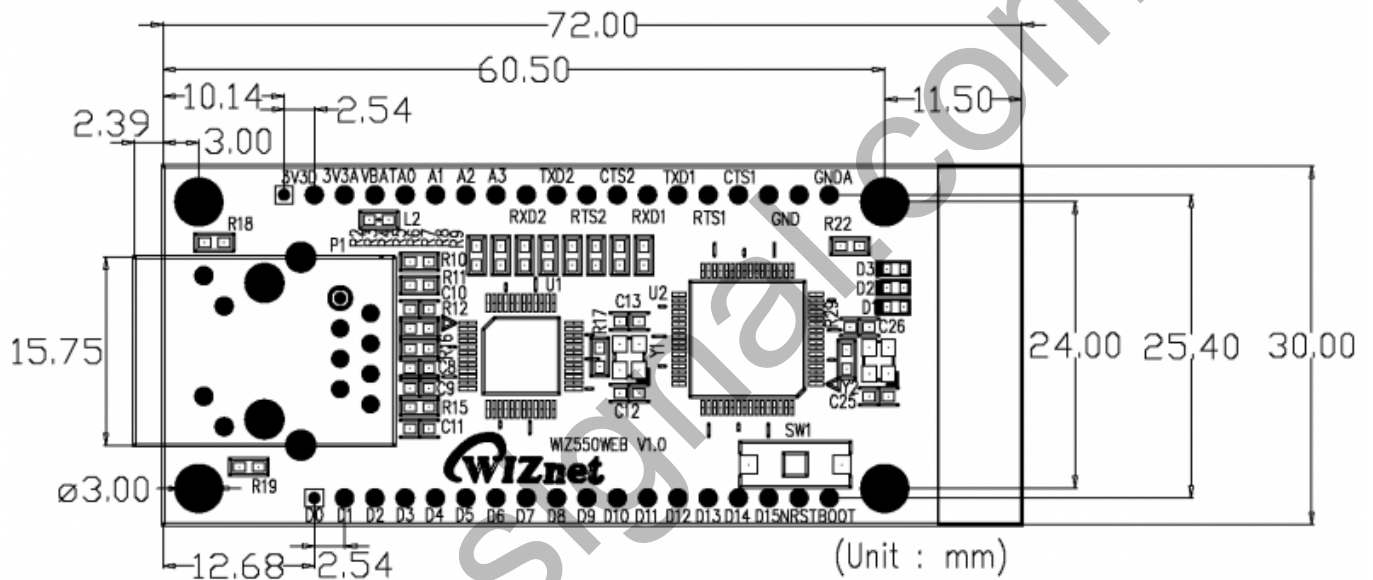

WIZ550web Baseboard

145mm(W) x 85mm(L) x 28mm(H) (±0.5)

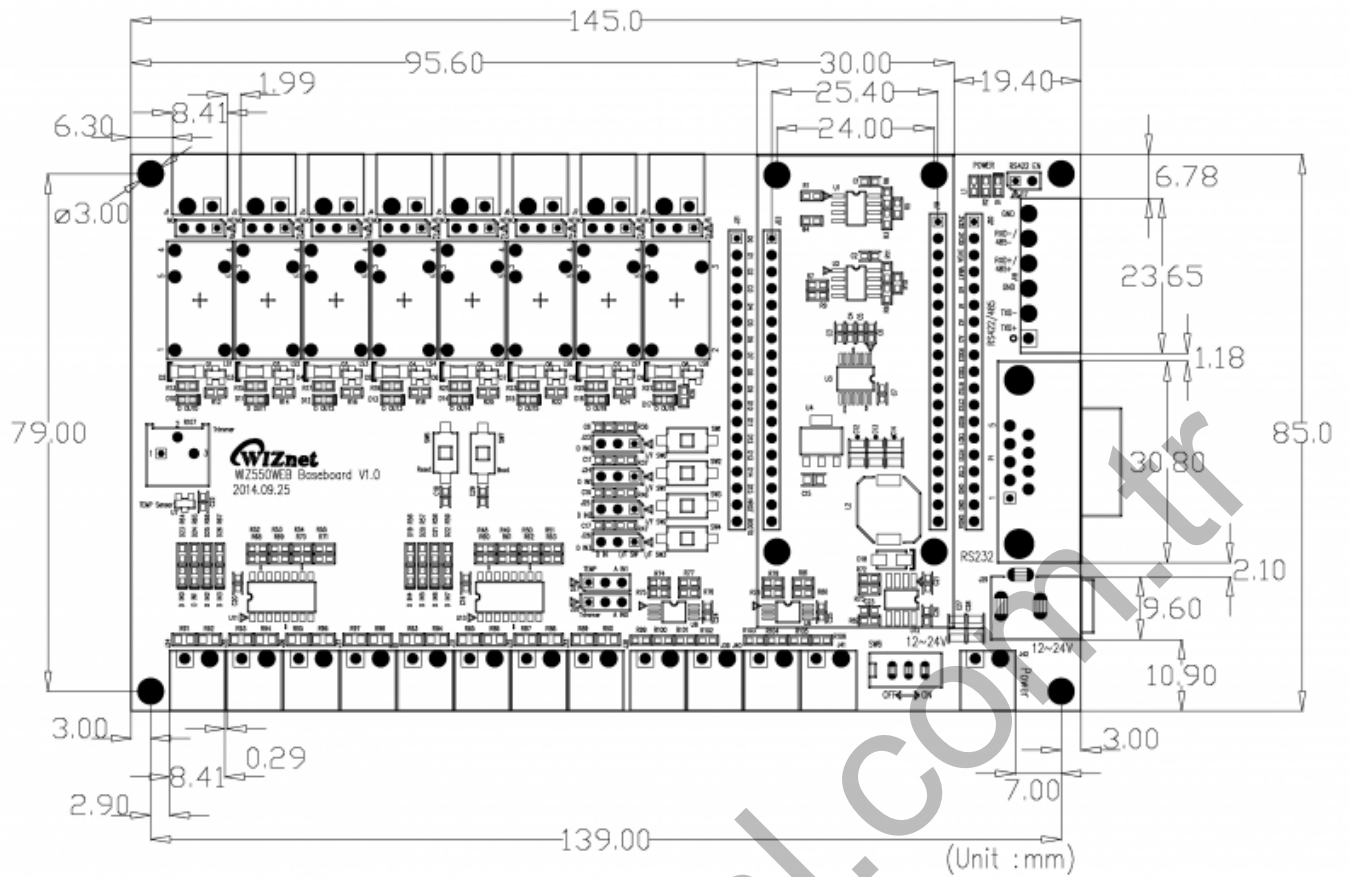

2014/10/28 13:18 · jeongsok

From:
<http://wizwiki.net/wiki/> -

Permanent link:
http://wizwiki.net/wiki/doku.php?id=products:wiz550web:wiz550webds_en

Last update: **2015/04/14 20:35**

