

■ Product introduction

UMW L9110S is a two-channel push-pull power amplifier ASIC designed to control the driving motor. It integrates discrete circuits into a single IC, which reduces the number of peripheral devices, reduces the cost and improves the reliability of the whole machine.

UMW L9110S chip has two input control terminals, which can control two output terminals to directly drive the forward and backward rotation of the motor. The chip is widely used in motor drive of toy cars, pulse electromagnetic valve drive, stepping motor drive, switching power tube and other circuits.

■ Product features

- The power supply range is 2.2~6.5V V.
- Low static working current
- Low saturation pressure drop
- TTL/CMOS output level is compatible and can be directly connected with CPU I/O.
- Few external devices
- Package: DIP8, SOP8

■ product usage

- Pulse electromagnetic valve drive
- Automobile motor drive
- Stepping motor drive
- Driving switch power tube

■ Package form and pin definition function

Pin serial number	Pin definition	Function description
1	OA	A Output pin
2	VCC	Positive pole of power supply
3	VCC	Positive pole of power supply
4	OB	B Output pin
5	GND	Power ground
6	IA	A Input terminal
7	IB	B Input terminal
8	GND	Power ground

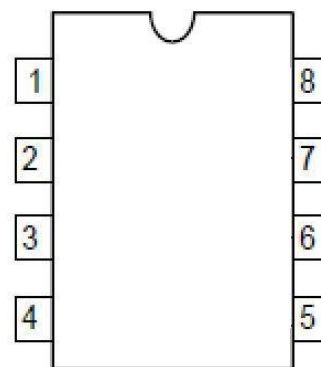

Limit parameter

project	symbol	explain	limit value	unit
voltage	V _{cc}	Power supply voltage	-0.3~+8.0	V
	V _{in}	input voltage	-0.3~VCC	V
dissipation power	P _o	SOP8/DIP8	500	mW
temperature	T _w	operating temperature range	-30—85	°C
	T _c	Storage temperature range	-50—125	
	T _h	welding temperature	260	°C,10s

Note: Limit parameter refers to the limit value that cannot be exceeded under any condition. If this limit value is exceeded, it may cause physical damage such as product deterioration. At the same time, when the parameters are close to the limit, the chip can not be guaranteed to work normally.

Electrical characteristic parameters (TA=25°C VCC=5V)

symbol	project	test condition	minimum	typical value	maximum	unit
VCC	operating voltage		2.2	5	6.5	V
ICC	quiescent current	operate without load		0.2	2	uA
IIN	incoming current	VIN=VDD or GND		0.1	2	uA
VINL	Input low voltage	IA, IB	0		0.25VCC	V
VINH	Input high voltage	IA, IB	0.7VCC		VCC	V
VAB1	output saturation voltage	IOUT=100mA		0.19	0.25	V
VAB2	output saturation voltage	IOUT=180mA		0.36	0.45	V

Input waveform diagram

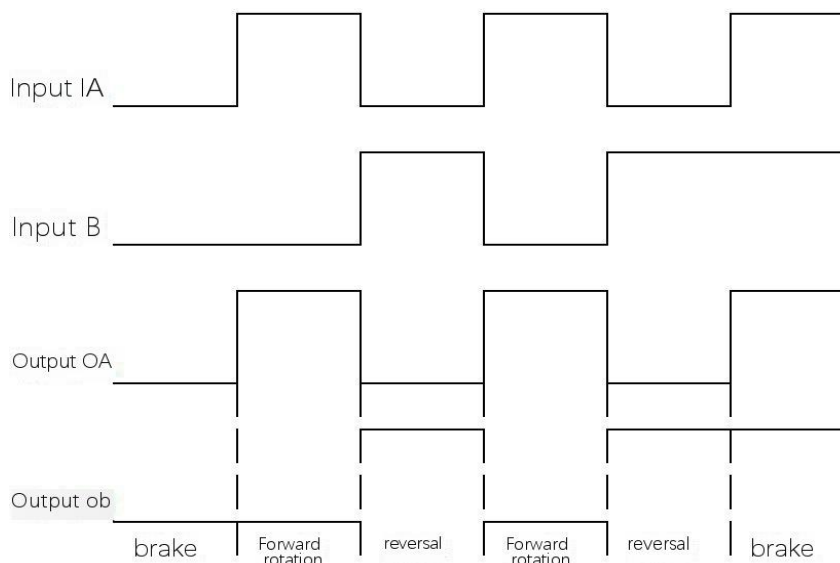

■ logic diagram

input		output		remarks
IA	IB	OA	OB	
L	L	L	L	apply the brakes
L	H	L	H	Forward/reverse rotation
H	L	H	L	Reverse/forward rotation
H	H	H	H	apply the brakes

■ Typical application

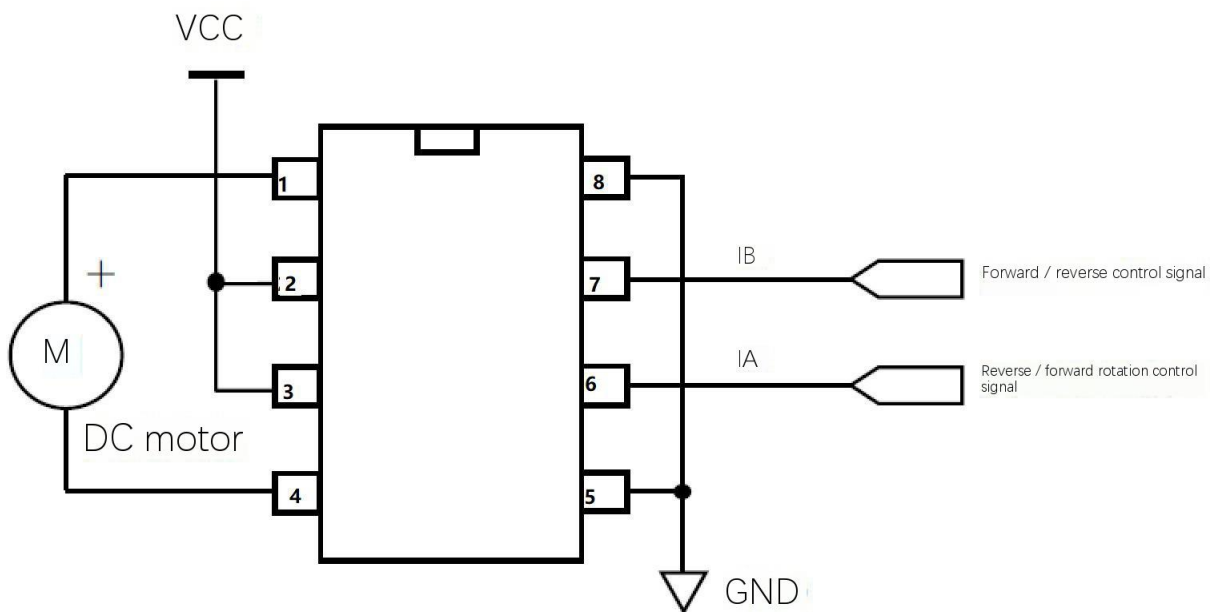

■ Encapsulation information

DIP 8

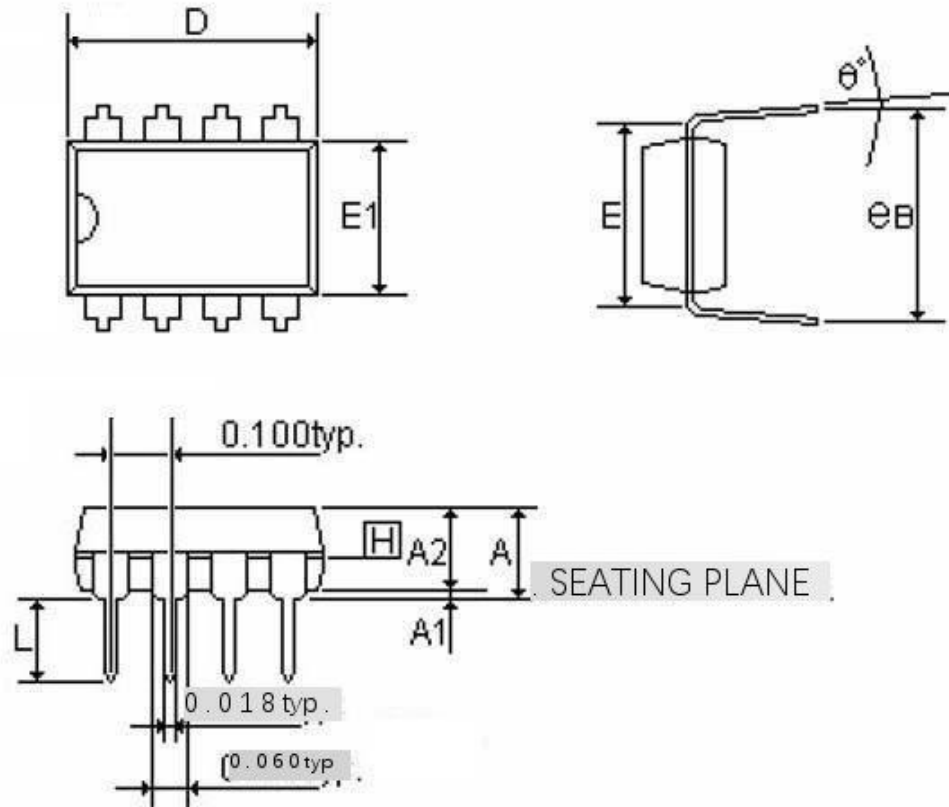

SYMBOLS	MIN	NOR	MAX	MIN	NOR	MAX
	(inch)			(mm)		
A	-	-	0.210	-	-	5.334
A1	0.015	-	-	0.381	-	-
A2	0.125	0.130	0.135	3.175	3.302	3.429
D	0.435	0.455	0.475	15.669	16.050	16.685
E	0.300			7.62		
E1	0.245	0.250	0.255	6.223	6.35	6.477
L	0.115	0.130	0.150	2.921	3.302	3.810
eB	0.335	0.355	0.375	8.509	9.017	9.525
θ°	0	70	15	0	70	15%

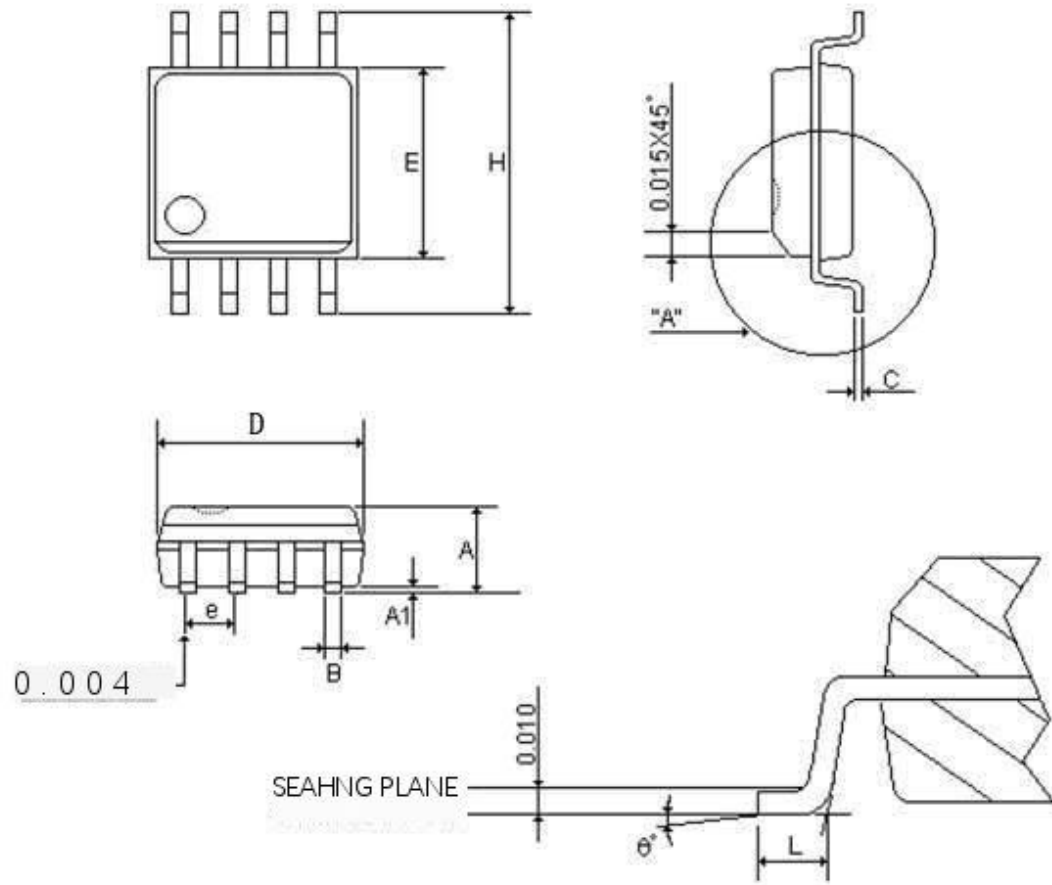

SYMBOLS	MIN	NOR	MAX	MIN	NOR	MAX
	(inch)			(mm)		
A	0.058	0.064	0.068	1.4732	1.6256	1.7272
M	0.004	-	0.010	0.1016	-	0.254
B	0.013	0.016	0.020	0.3302	0.4064	0.508
B	0.0075	0.008	0.0098	0.1905	0.2032	0.2490
D	0.186	0.191	0.196	5.9944	6.1214	6.1976
E	0.150	0.154	0.157	3.81	3.9116	3.9878
E	-	0.050	-	-	1.27	-
H	0.228	0.236	0.244	5.7912	5.9944	6.1976
H	0.015	0.025	0.050	0.381	0.635	1.27
θ	0°	-	8°	0°	-	8°