



WS2812B-Mini-V3J

Intelligent external control LED
Integrated light source

Features and Benefits

- The IC's control circuit and the LED share the same power supply.
- Control circuit and RGB chip are integrated in a package of 3535 component, to form a complete external control pixel.
- Built-in signal reshaping circuit, any pixel receives the signal, and then re-export after waveform reshaping to ensure that the waveform distortion of the circuit will not accumulate.
- Built-in Power-on reset and Power-off reset circuits.
- The three primary color of each pixel can achieve 256 level Gray scale, and to fulfill 16777216 colors full-color display, its scan frequency is higher than 2KHz.
- The reception and decoding of cascading data can be completed by a Serial Interface.
- Any two transmission distance not more than 3 Meters, without adding any circuit.
- When the refresh rate is of 30fps, the cascade numbers are not less than 1024 pixels.
- Data transfer speeds up to 800Kbps.
- Highly brightness consistency, and cost-effective.
- No need for external electric components and even the capacitor.
- It won't be damaged even if the power supply reversed connected.

Applications

- LED embedded illuminated keyboards and mice.
- Full-color module, Full-color flexible strip.
- LED decorative lighting, Indoor/outdoor LED video irregular screen.

General description

WS2812B-Mini-V3J is an intelligent control LED light source that the control circuit and RGB chip are integrated in a package of 3535 component. It internal include intelligent digital port data latch and signal reshaping amplification drive circuit. It also includes a high-precision internal oscillator and a programmable constant current control part to ensure high color consistency.

The data transfer protocol use single NZR communication mode. After the pixel power-on reset, the DIN port receive data from controller, the first pixel collect initial 24bit data then sent to the internal data latch, the other data which reshaping by the internal signal reshaping amplification circuit sent to the next cascade pixel through the DO port. After transmission for each pixel, the signal to reduce 24bit. pixel adopt auto reshaping transmit technology, making the pixel cascade number is not limited the signal transmission, only depend on the speed of signal transmission.

RESET time > 280μs , it won't cause wrong reset while interruption, it supports the lower frequency and inexpensive MCU.

Refresh Frequency updates to 2KHz, Low Frame Frequency and No Flicker appear in HD Video Camera, it improve excellent display effect.

LED with low driving voltage, environmental protection and energy saving, high brightness, scattering angle is large, good consistency, low power, long life and other advantages. The control chip integrated in LED above becoming more simple circuit, small volume, convenient installation.

Mechanical Dimensions

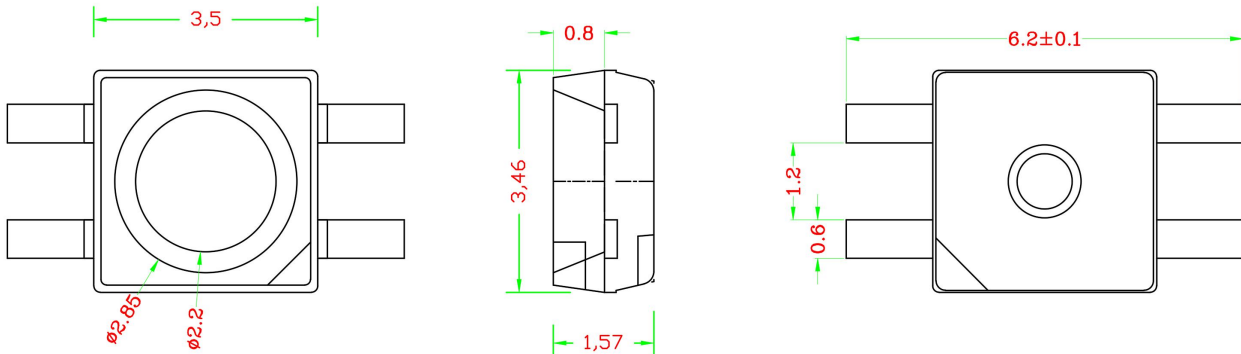

PIN Configurations

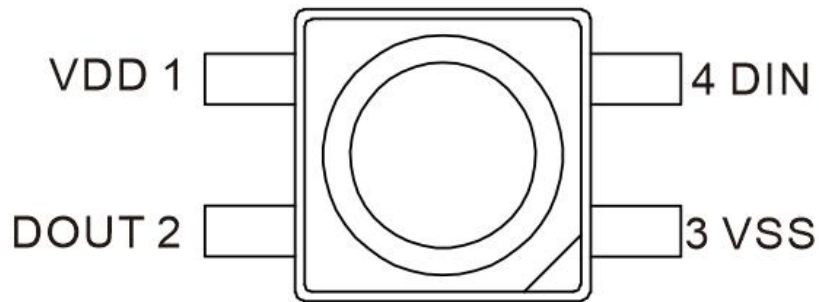

PIN Functions

NO.	Symbol	Function description
1	VDD	LED Power supply
2	DOUT	Control data signal output
3	VSS	Ground
4	DIN	Control data signal input

Absolute Maximum Ratings

Parameter	Symbol	Ratings	Unit
Power supply voltage	V_{DD}	+3.7~+5.3	V
Logical Input Voltage	V_I	0.3V ~ $V_{DD}+0.7V$	V
Operation junction temperature	T_{opt}	-25 ~ +65	°C
Storage temperature range	T_{stg}	-40~+85	°C



WS2812B-Mini-V3J

Intelligent external control LED
Integrated light source

Electrical Characteristics ($T_A=25^{\circ}\text{C}$, $V_{DD}=5\text{V}$, $\text{GND}=0\text{V}$)

Parameter	Symbol	Min	Tpy	Max	Unit	Condition
Input current	I_I	—	—	± 1	μA	$V_I=V_{DD}/V_{SS}$
Input voltage level	V_{IH}	2.7V	$V_{DD}+0.7\text{V}$		V	D_{IN}, SET
	V_{IL}	-0.3V	—	0.7V	V	D_{IN}, SET
Hysteresis voltage	V_{IH}	—	0.35	—	V	D_{IN}, SET

Switching Characteristics ($T_A=25^{\circ}\text{C}$, $V_{DD}=5\text{V}$, $\text{GND}=0\text{V}$)

Parameter	Symbol	Min	Tpy	Max	Unit	Condition
Transmission delay time	T_{PLZ}	—	—	300	ns	$CL=15\text{pF}$, $D_{IN} \rightarrow D_{OUT}$, $RL=10\text{K}\Omega$
Fall time	T_{THZ}	—	—	120	μs	$CL=300\text{pF}$, $OUTR/OUTG/OUTB$
Input capacity	C_I	—	—	15	pF	—

LED Characteristics ($\text{DC}=5\text{V}$, $T_a=25^{\circ}\text{C}$)

Parameter	Symbol	Color	Quiescent Current<0.6mA				Condition (Working current)
			Min	Tpy	Max	Unit	
Luminous intensity	IV	RED	300	350	400	mcd	12mA
		GREEN	800	900	1000		
		BLUE	200	250	300		
Wavelength	λ_d	RED	620	--	625	nm	12mA
		GREEN	525	--	530		
		BLUE	465	--	470		

BIN Selecting

BIN	X1	Y1	X2	Y2	X3	Y3	X4	Y4
1	0.24	0.23	0.24	0.25	0.26	0.27	0.26	0.25

Data Transfer Time

T0H	0 code, high voltage time	220ns~380ns
T1H	1 code, high voltage time	580ns~1 μs
T0L	0 code, low voltage time	580ns~1 μs
T1L	1 code, low voltage time	580ns~1μs
RES	low voltage time	> 280 μs

Sequence chart

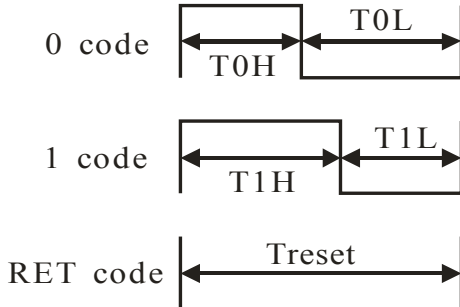

Cascade Method

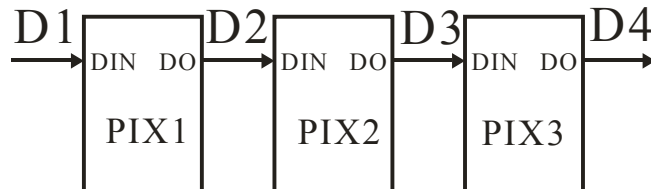

Data Transmission Method

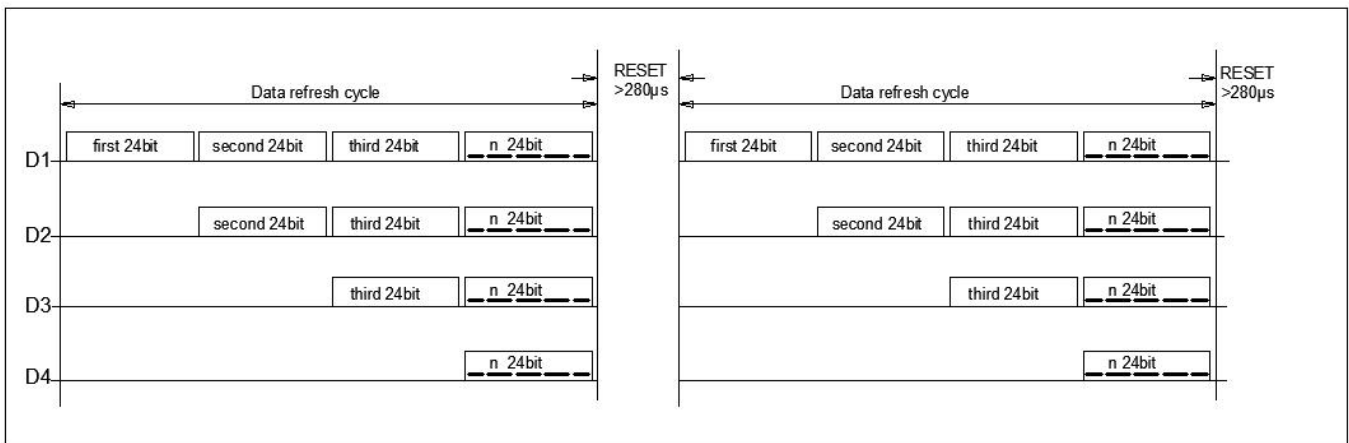

Note: The data of D1 is sent by MCU, and D2, D3, D4 through pixel internal reshaping amplification to transmit.

Composition of 24bit Data

G7	G6	G5	G4	G3	G2	G1	G0	R7	R6	R5	R4	R3	R2	R1	R0	B7	B6	B5	B4	B3	B2	B1	B0
----	----	----	----	----	----	----	----	----	----	----	----	----	----	----	----	----	----	----	----	----	----	----	----

Note: Follow the order of GRB to send data and the high bit sent at first.

Typical Application Circuit (No need for external filter capacitor)

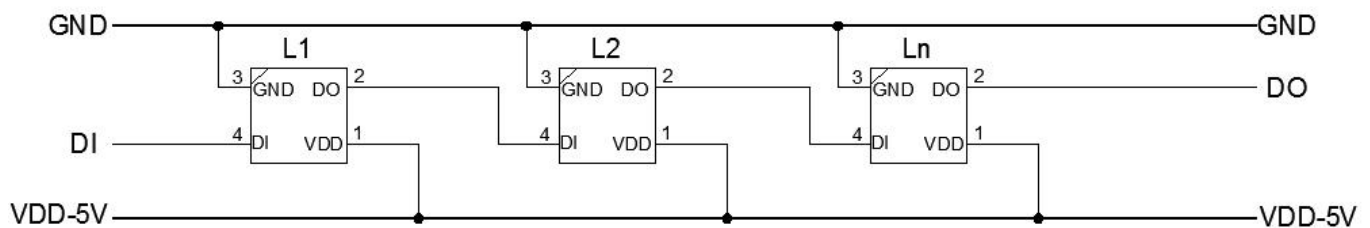

Note: It's recommended to add a 100nf value of filter capacitor between GND and VDD.



WS2812B-Mini-V3J

Intelligent external control LED
Integrated light source

Top SMD LED Using Instructions

1. Summary

To make the best use of WORLDSEMI's LED, please refer to the below precautions, they are of same usage method as other electronic components.

2. Cautions

2.1. Dust & Cleaning

The surface of the LED is encapsulated with modified epoxy resin because it plays a very good role in protecting the optical performance and aging resistance. The modified epoxy resin is easy to stick with dust and must be kept clean. When there's a certain amount of dust on the surface of the LED, it won't affect brightness, but dust proof should be taken care of. Promoting the use of unsealed package in preference to others and the assembled LEDs should be placed in a clean container.

Avoid using the organic solvents to clean the dust on the LED surface and it's necessary to confirm whether the cleaning fluid will dissolve the LED.

Do not clean the LEDs by the ultrasonic. Some parameters affecting the LED performance must be evaluated if have no alternative but to the ultrasonic cleaning method, such as ultrasonic power, baking time and assembly conditions, etc.

2.2. Moisture-proof packaging

TOP SMD LEDs are moisture sensitive components. LEDs are packaged in aluminum foil bag to prevent the from absorbing moisture during transport and storage. A desiccant is placed in the bags to absorb moisture. If the LED absorbs moisture, then it evaporates and expands when in reflow process, which may break the colloid from the bracket and damage the optical performance of LED. For this reason, moisture-proof packaging is to prevent the from absorbing moisture during transport and storage. The moisture resistance rating of WORLDSEMI's LED is: **LEVEL 5a**.

Table I - IPC/JEDEC J-STD-020 Moisture/Reflow Sensitivity Classification

MSL Level	Workshop Life	
	Time	Conditions
LEVEL1	Unlimited	≤30°C /85%RH
LEVEL2	1 Year	≤30°C /60%RH
LEVEL2a	4 Weeks	≤30°C /60%RH
LEVEL3	168 Hours	≤30°C /60%RH
LEVEL4	72 Hours	≤30°C /60%RH
LEVEL5	48 Hours	≤30°C /60%RH
LEVEL5a	24 Hours	≤30°C /60%RH
LEVEL6	Take-out and Use immediately	≤30°C /60%RH

2.3 SMT Instruction:

2.3.1 It is recommended that opening the Vacuum plastic bag before SMT, and put the whole reel into the oven for dehumidification and drying (Bake at 70 ~ 75°C ≥24H);

2.3.2 From the led taken out of the oven to the completion of high temperature welding (including multiple reflow welding, tin immersion, wave soldering, heating maintenance and other high temperature operations/operations), the time period shall be controlled within 24Hours (Under condition of $T < 30^{\circ}\text{C}$, $\text{RH} < 60\%$);

2.3.3 After the LED paste is printed on the PCBA, SMT process should be completed as soon as possible, it is recommended not to exceed 1H;

2.3.4 Bulk material LED, such as production surplus, machine material, maintenance material, can not be used directly if exposed to the air for a long time. It is recommended to be dehumidified and dried before being used.

Whole reel baking: $70 \sim 75^{\circ}\text{C} * \geq 24\text{H}$ or bulk led baking: $120^{\circ}\text{C} * 4\text{H}$.

3. SMT Reflow Soldering

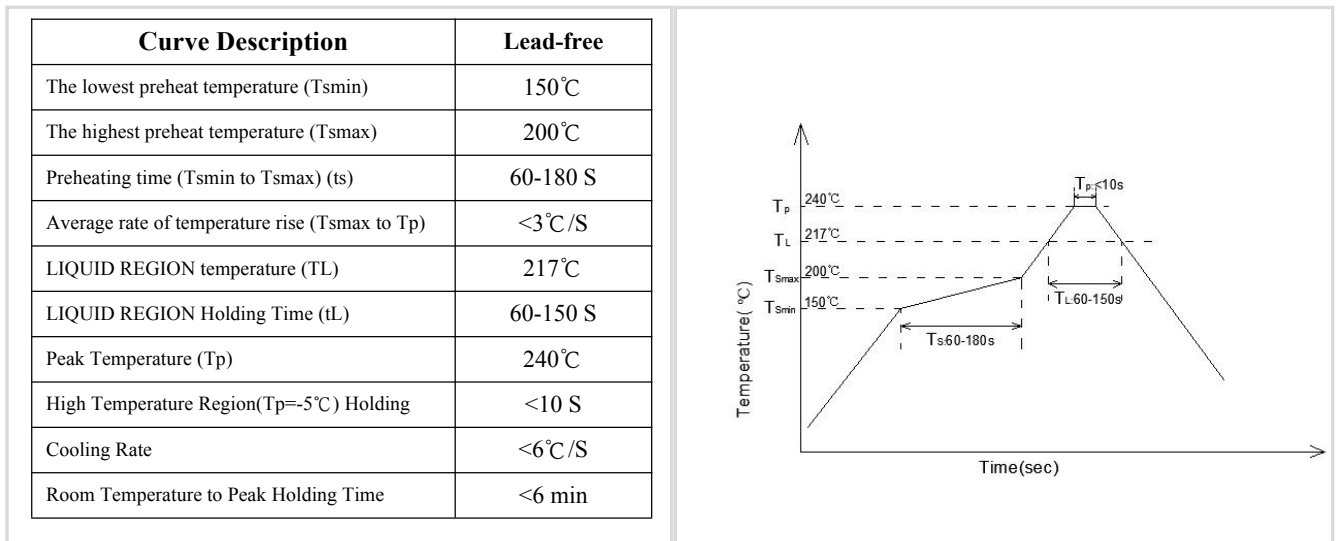

Refer to the parameters listed below, the experimental results prove that the TOP SMD LED meets the JEDEC J-STD-020C standards. As a general guideline, it is recommended to follow the SMT reflow temperature curve recommended by the solder paste manufacturer.



Remarks: 1. These general guidelines may not apply to all PCB designs and reflow soldering configurations.

2. All temperatures referred are measured on the surface of the package body.

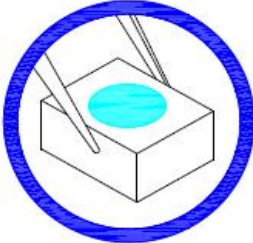
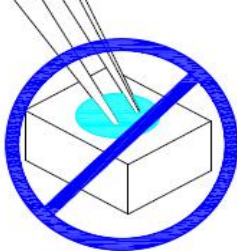
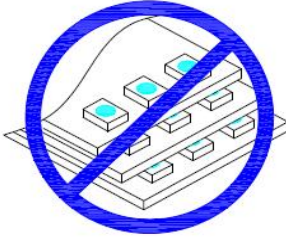
4. Assembly Precautions

1. Clip the LED from its side.	2. Neither directly touch the gel surface with the hand or sharp instrument, it may damage its internal circuit.
	
3. Not to be double stacked, it may damage its internal circuit.	4. Can not be stored in or applied in the acidic sites of PH<7.
	

Modify Record

Version №	Status Bar	Modify Content Summary	Date	Reviser	Approved
V1.0	N	New	20181001	Shen JinGuo	Yin HuaPing
V1.1	M	Parameters modification	20190115	Shen JinGuo	Yin HuaPing
V1.2	M	LED bracket upgraded	20211123	Yu XingHui	Yin HuaPing

Remarks: Initial version: V1.0; Version number plus "0.1" after each revision;

Status bar: N--New, A--Add, M--Modify, D--Delete.