

Features description

TM1637 is a kind of LED (light-emitting diode display) drive control special circuit with keyboard scan interface and it's internally integrated with MCU digital interface, data latch, LED high pressure drive and keyboard scan. This product is in DIP20/SOP20 package type with excellent performance and high quality, which is mainly applicable to the display drive of induction cooker, micro-wave oven and small household electrical appliance.

Function features

- Applied power CMOS technique
- The display mode (8 segments*6 bit) supports output by common anode LED.
- Keyboard scan (8×2bit), with enhanced identification circuit with anti-interference keys
- Luminance adjustment circuit (adjustable 8 duty ratio)
- Two-wire serial interface (CLK, DIO)
- Oscillating type: Built-in RC oscillator
- Built-in power-on reset circuit
- Built-in automatic blanking circuit
- Package type: DIP20/SOP20

Pin information

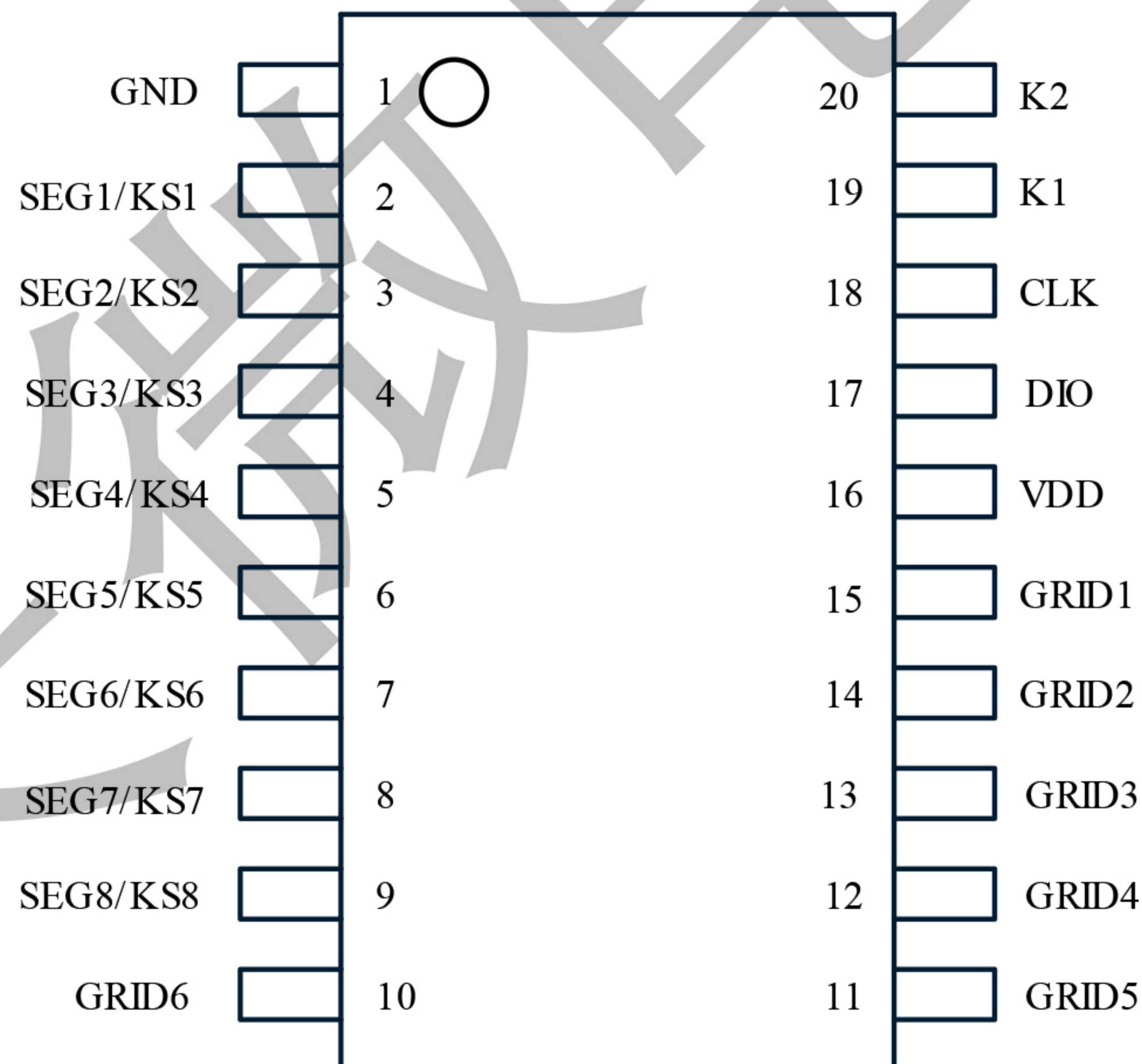

Pin functions

Symbols	Pin name	Pin No.	Description
DIO	Data input/output	17	It is used for serial data input and output. The input data has a low level fluctuation while high level transfer at SCLK. Once one bit is transferred, one ACK is generated at falling edge of the 8 th clock inside the chip.
CLK	Clock input	18	It is used for data input and output at rising edge.
K1~K2	Data input by keyboard scan	19-20	Inputting the pin data here and it will be latched when the display cycle is over.
SG1~SG8	Output (segment)	2-9	Segment Output (also keyboard scan) and N-channel open drain output
GRID6~GRID1	Output (bit)	10-15	Bit output and P-channel open drain output
VDD	Logic Supply	16	Anode power connection
GND	logic ground	1	Grounding connection



Electrostatic discharge led by much static at dry weather or environment could damage the integrated circuit. TITAN MICRO ELECTRONICS suggests you to take every measure to protect integrated circuit. ESD damage or decreased performance by inappropriate operation or welding could lead to chip failure.

Read the key scan data

Key scan matrix of 8×2bit is shown as the following:

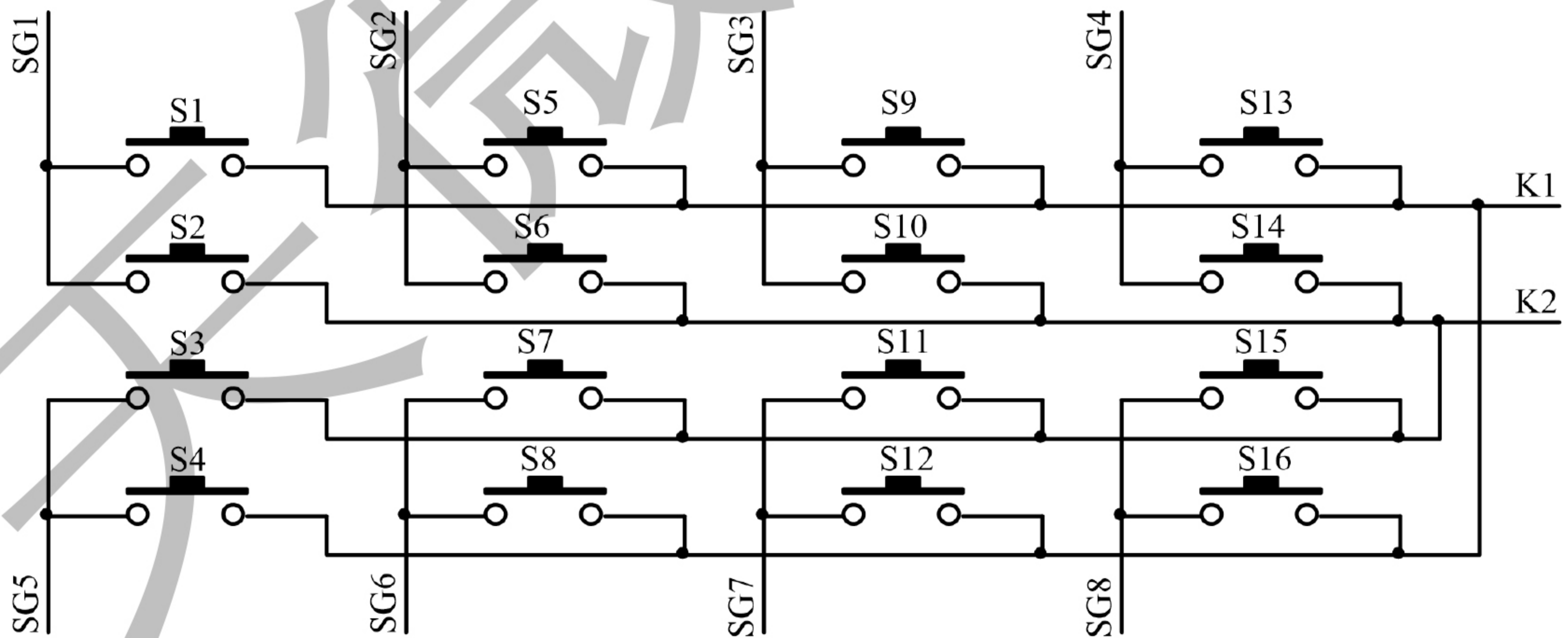

When a key is pressed, the key scan data is as follows: (Where low level is forward and high level is backward, 1110_1111 stands for 0xF7).

	SG1	SG2	SG3	SG4	SG5	SG6	SG7	SG8
K1	1110_1111	0110_1111	1010_1111	0010_1111	1100_1111	0100_1111	1000_1111	0000_1111
K2	1111_0111	0111_0111	1011_0111	0011_0111	1101_0111	0101_0111	1001_0111	0001_0111

Note: Where there is no key pressed down, the key read data should be 1111_1111 with forward low level and backward high level. Since strong interference exists in the use of kitchen appliances, such as induction cooker, negative edge trigger mode was applied in TM1637 to avoid mistake trigger, which is also the called “key jumping”. TM 1637 doesn’t support combined key pressing.

Display register address

Stored data in the register is transferred to the TM1637 from outside elements by serial interface, with 6 bytes units of address from C0H to C5H in correspondence with the LED lights connected with SEG pin and GRID pin on the chip. LED data is displayed from low level to high level in respect of display address, and should be operated from low level to high level in respect of data bytes.

SEG1	SEG2	SEG3	SEG4	SEG5	SEG6	SEG7	SEG8	
xxHL (low four bits)				xxHU (high four bits)				
B0	B1	B2	B3	B4	B5	B6	B7	
C0HL				C0HU				GRID1
C1HL				C1HU				GRID2
C2HL				C2HU				GRID3
C3HL				C3HU				GRID4
C4HL				C4HU				GRID5
C5HL				C5HU				GRID6

Interface interpretation

Microprocessor data realize the communication with TM1637 by means of two-wire bus interface (Note: The communication method is not equal to I2C bus protocol totally because there is no slave address). When data is input, DIO signal should not change for high level CLK and DIO signal should change for low level CLK signal. When CLK is a high level and DIO changes from high to low level, data input starts. When CLK is a high level and DIO changes from low level to high level, data input ends.

TM1637 data transfer carries with answering signal ACK. For a right data transfer, an answering signal ACK is generated inside the chip to lower the DIO pin at the falling edge of the 8th clock. DIO interface wire is released at the end of the 9th clock.

1、 Command data transfer is as follows (Reading Key Data Timing)

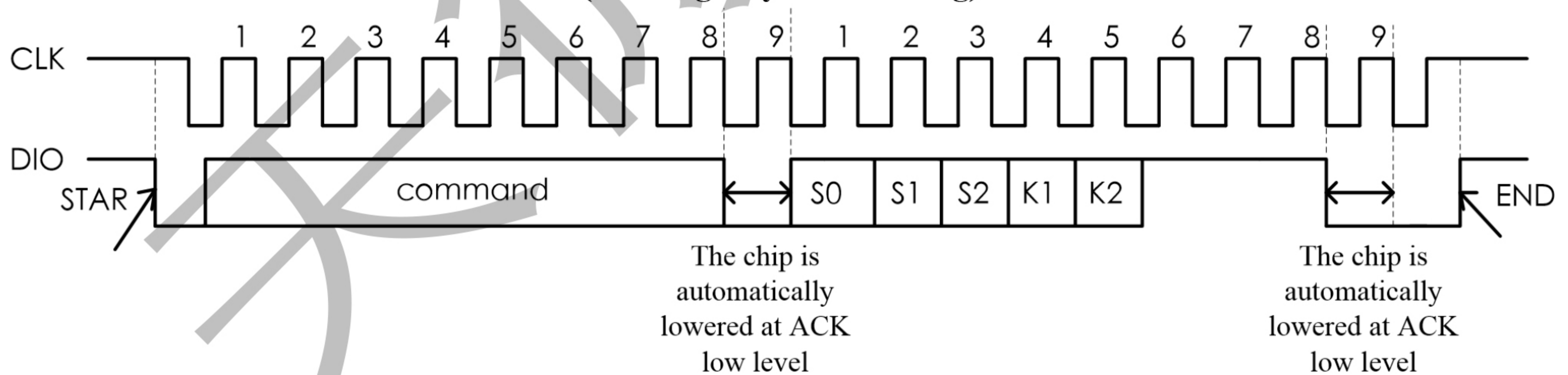

Command: command to read the keys; Key information coding consists of S0, S1, S2, K1 and K2. S_{Gn} coding consists of S0, S1, and S2. K1 and K2 are coding for K1 key and K2 key. The key should be read from low level to high level and the clock frequency should be less than 250K.

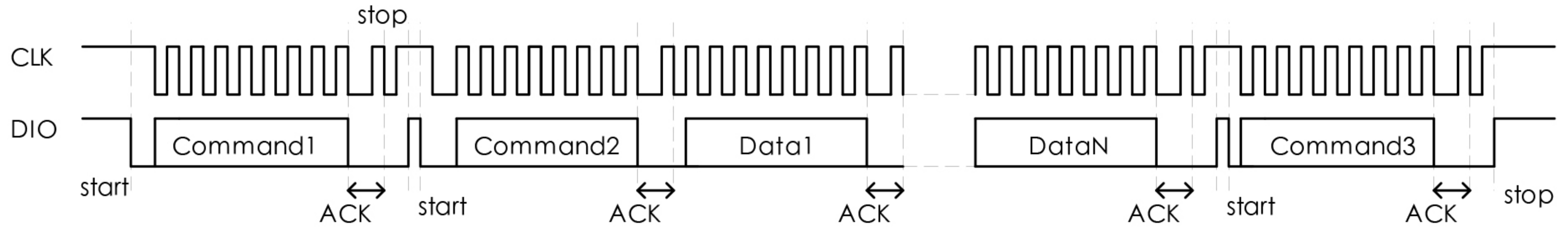
2、 Write SRAM data in address auto increment 1 mode.

Command1: Set data
 Command2: Set address
 Data1~N: Transfer display data
 Command3: Control display

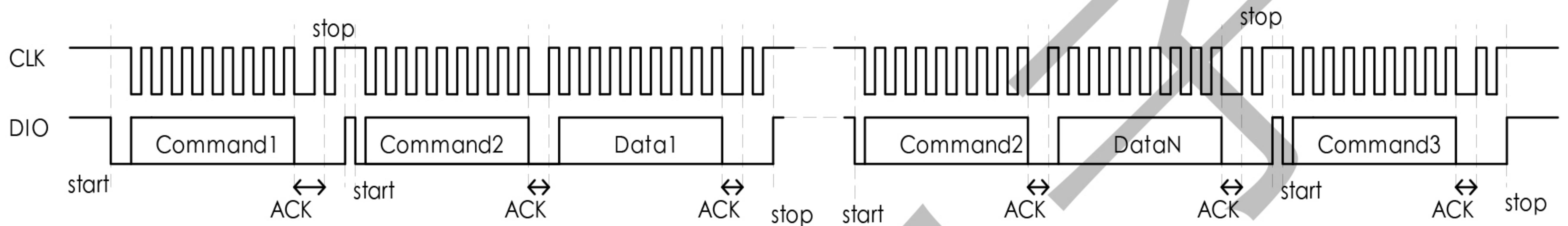
3、 Write SRAM data in a fixed address mode

Command1: Set data
 Command2: Set data
 Data1~N: Transfer display data
 Command3: Control display

Data command

Command is used to set the display mode and the LED driver status.

The first byte input from DIO at CLK falling edge acts as a command. The highest B7 and B6 bytes after decoding are used to distinguish different commands.

B7	B6	Command
0	1	Data command setting
1	0	Display and control command setting
1	1	Address command setting

When STOP command is sent during command or data transfer, serial communication is initialized and command or data transferring becomes invalid (Command or data transferred before remain effective.).

1、 Data command setting

This command is to set data write and data read. 01 and 11 are not permitted to set for B1 and B0 bits.

MSB
LSB

B7	B6	B5	B4	B3	B2	B1	B0	Function	Description
0	1	Zero should be inserted for irrelevant items.				0	0	Data write and read mode setting	Write data to display register
0	1					1	0		Read key scan data
0	1					0		Address adding mode setting	Automatic address adding
0	1					1			Fix address
0	1				0			Test mode setting (for internal)	Normal mode
0	1				1				Test mode

2、 Address command setting

MSB				LSB				Display address
B7	B6	B5	B4	B3	B2	B1	B0	
1	1	Zero should be inserted for irrelevant items.		0	0	0	0	C0H
1	1		0	0	0	1	C1H	
1	1		0	0	1	0	C2H	
1	1		0	0	1	1	C3H	
1	1		0	1	0	0	C4H	
1	1		0	1	0	1	C5H	

The command is used to set the display register address. If the address is set as C6H or a higher one, the data will be ignored until effective address is set. Once electrified, the default address is C0H.

3、 Display control

MSB				LSB				Function	Description	
B7	B6	B5	B4	B3	B2	B1	B0			
1	0	Zero should be inserted for irrelevant items.			0	0	0	Setting of extinction number	1/16 Pulse width is set as 1/16.	
1	0				0	0	1		2/16 Pulse width is set as 2/16	
1	0					0	1		0	4/16 Pulse width is set as 4/16
1	0					0	1		1	10/16 Pulse width is set as 10/16
1	0					1	0		0	11/16 Pulse width is set as 11/16
1	0					1	0		1	12/16 Pulse width is set as 12/16
1	0					1	1		0	13/16 Pulse width is set as 13/16
1	0					1	1		1	14/16 Pulse width is set as 14/16
1	0			0				Display switch setting	Display OFF	
1	0			1					Display ON	

Program flow chart

1、 Flow chart of program using address auto increment 1 mode

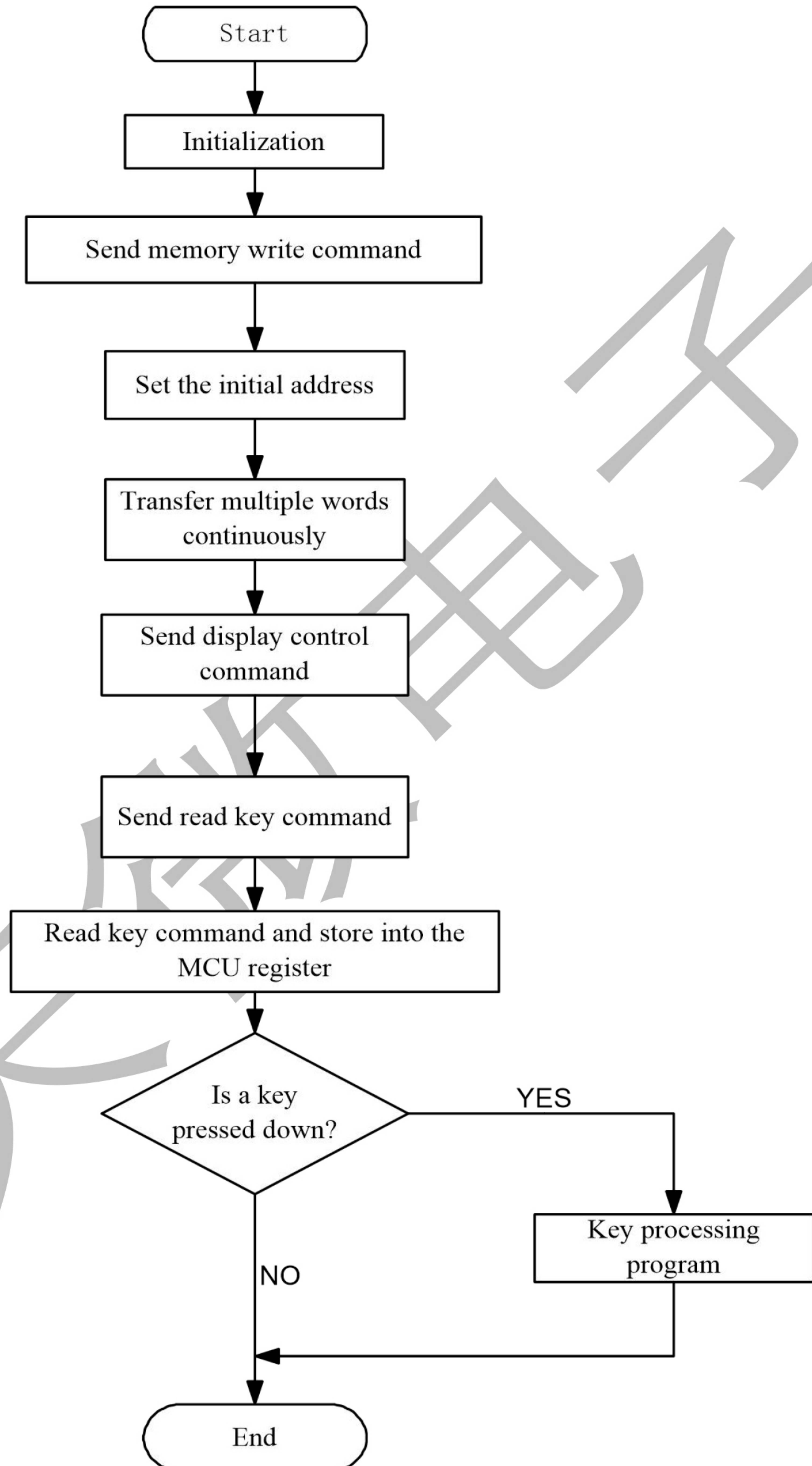

2、 Flow chart of program design using fixed address

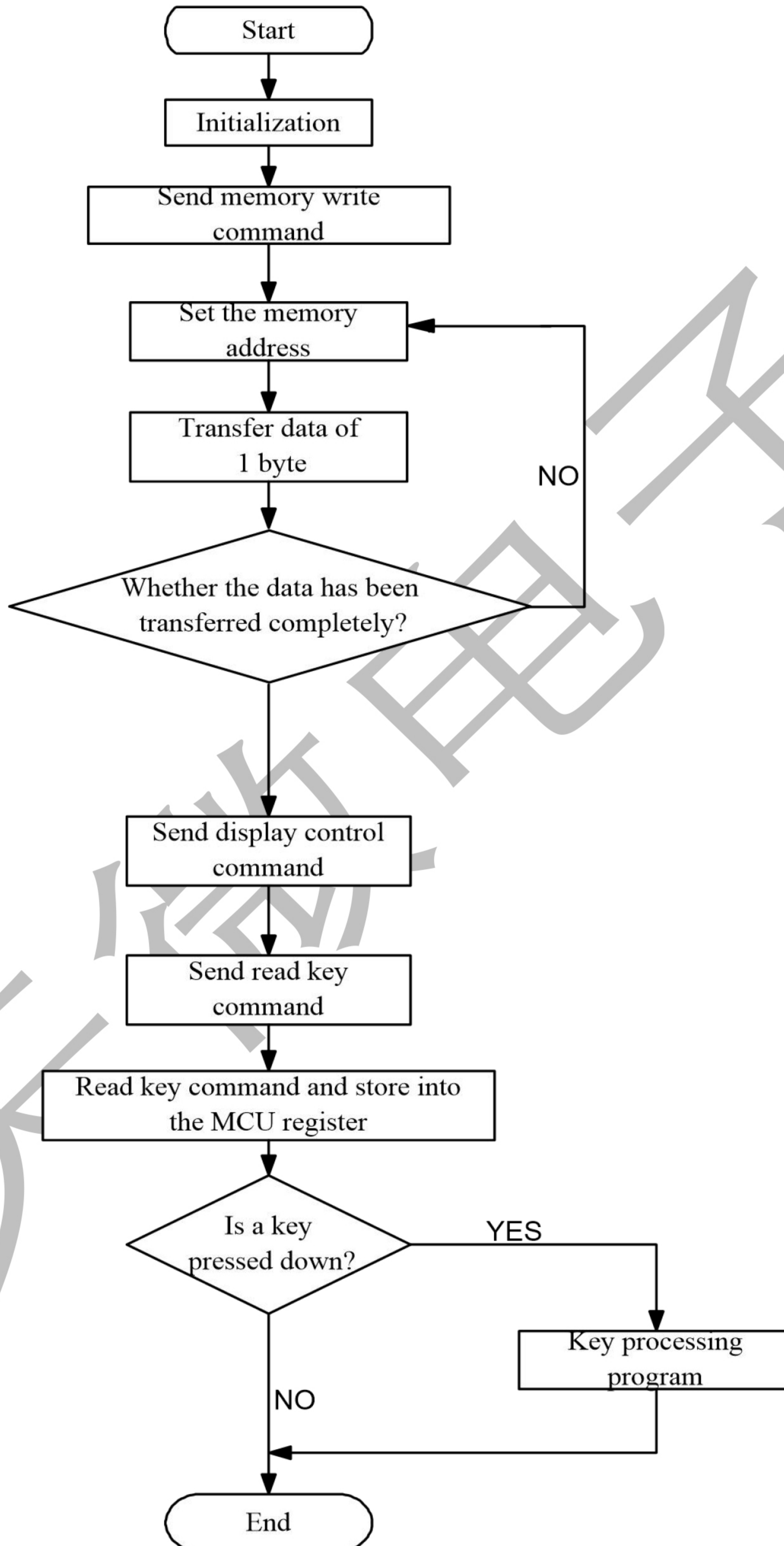

Hardware connection drawing

Nixie tube in circuit diagram is common anode one.

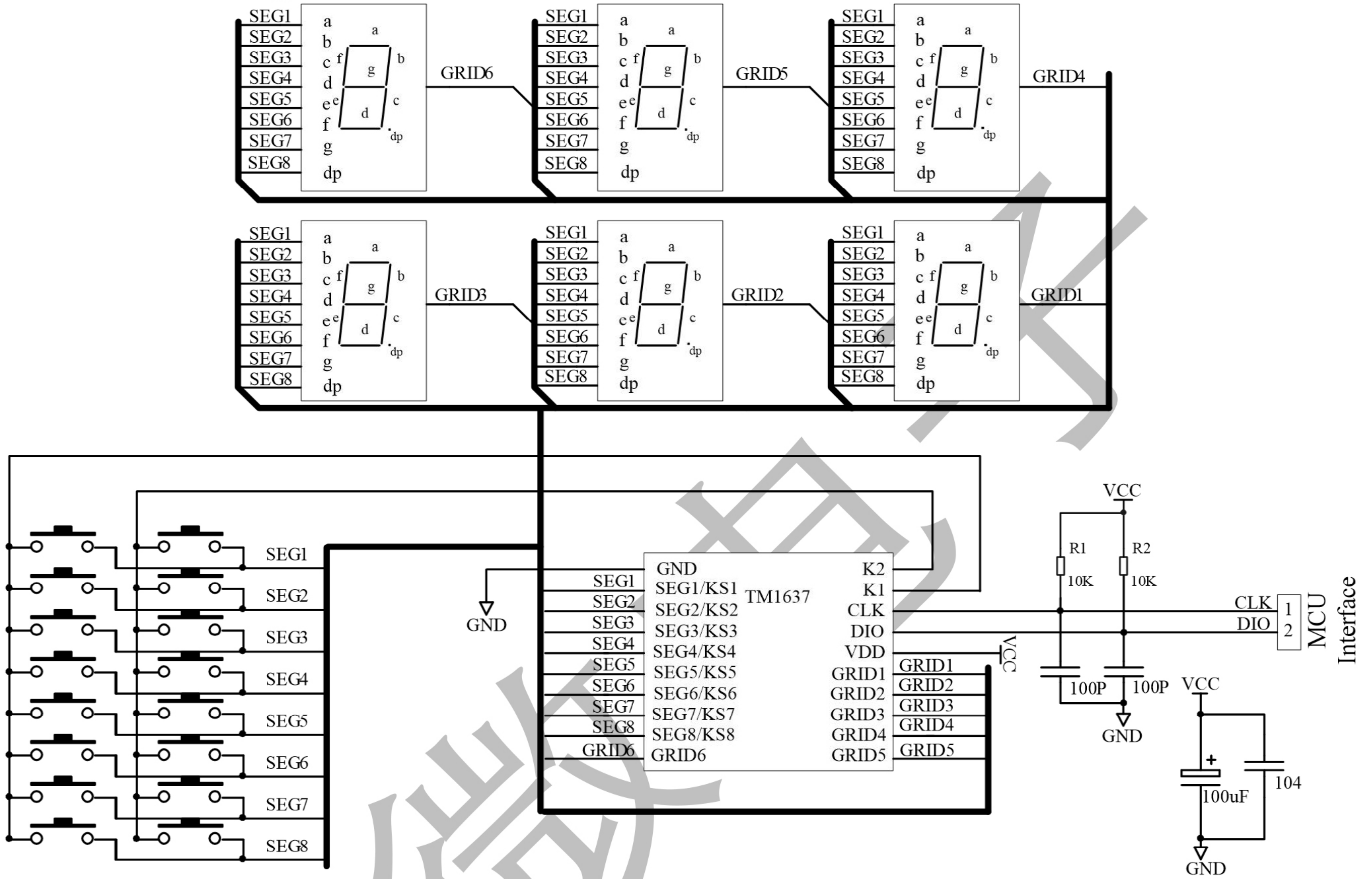

Note: 1. filtering capacitor between VDD and GND should be arranged on PCB plate as close to TM1637 chip as possible to strengthen filtering effect.

2. 100pF capacitor connected to the DIO, CLK communication port pull-up and pull-down can reduce interference to radio communications port.

3. Since blue-ray nixie tube break over step-down voltage is 3V, TM1637 power supply should be 5V.

Electrical parameter

1、 Limit parameter (Ta = 25°C, Vss = 0 V)

Parameters	Symbol	Range	Unit
Logic power supply voltage	VDD	-0.5 ~ +7.0	V
Logic input voltage	VII	-0.5 ~ VDD + 0.5	V
LED and SEG drive sink current	IO1	50	mA
LED and GRID drive source current	IO2	200	mA
Power loss	PD	400	mW
Work temperature	Topt	-40 ~ +85	°C
Storage temperature	Tstg	-65 ~ +150	°C

2、 Normal working range (Vss = 0 V)

Parameters	Symbol	Minimum	Typical	Maximum	Unit	Test condition
Logic power supply voltage	VDD		5		V	-
High-level input voltage	VIH	0.7 VDD	-	VDD	V	-
Low-level input voltage	VIL	0	-	0.3 VDD	V	-

3、 Electrical character (VDD = 4.5 - 5.5 V, Vss = 0 V)

Parameters	Symbol	Minimum	Typical	Maximum	Unit	Test condition
GRID drive source current	Ioh1	80	120	180	mA	GRID1~GRID6, Vo = vdd-2V
	Ioh2	80	140	200	mA	GRID1~GRID6, Vo = vdd-3V
SEG drive sink current	IOL1	20	30	50	mA	SEG1~SEG8 Vo=0.3V
DOUT pin output low current	Idout	4	-	-	mA	Vo = 0.4V, dout
High-level output current tolerance	Itolsg	-	-	5	%	Vo = VDD - 3V, GRID1~GRID6

Output pull down resistor	RL		10		K Ω	K1~K2
Input current	II	-	-	± 1	μA	VI = VDD / VSS
High-level input voltage	VIH	0.7 VDD	-		V	CLK, DIN
Low-level input voltage	VIL	-	-	0.3 VDD	V	CLK, DIN
Lagging voltage	VH	-	0.35	-	V	CLK, DIN
dynamic current loss	IDDdyn	-	-	5	mA	Non-loaded, display OFF

4、 Switching character (VDD = 4.5 - 5.5 V, Vss = 0 V)

Parameters	Symbol	Mini mum	Typical	Maxi mum	Unit	Test condition	
oscillation frequency	fosc	-	450	-	KHz		
Transmission delay time	tPLZ	-	-	300	ns	CLK \rightarrow DIO	
	tPZL	-	-	100	ns	CL = 15pF, RL = 10K Ω	
Rise time	TTZH 1	-	-	2	μs	CL = 300p F	GRID1 ~ GRID6
	TTZH 2	-	-	0.5	μs		SEG1 ~ SEG8
Fall time	TTHZ	-	-	120	μs	CL = 300pF, Segn, Gridn	
Maximum clock frequency	Fmax	-	-	500	KHz	占空比50% 50% duty ratio	
Input capacitance	CI	-	-	15	pF	-	

5、 Timing character (VDD = 4.5 - 5.5 V, Vss = 0 V)

Parameters	Symbol	Minimu m	Typical	Maximu m	Unit	Test condition
Clock pulse width	PWCLK	400	-	-	ns	-
Data setup time	tSETUP	100	-	-	ns	-
Data hold time	tHOLD	100	-	-	ns	-
Waiting time	tWAIT	1	-	-	μs	CLK \uparrow \rightarrow CLK \downarrow

IC Package diagram
DIP20

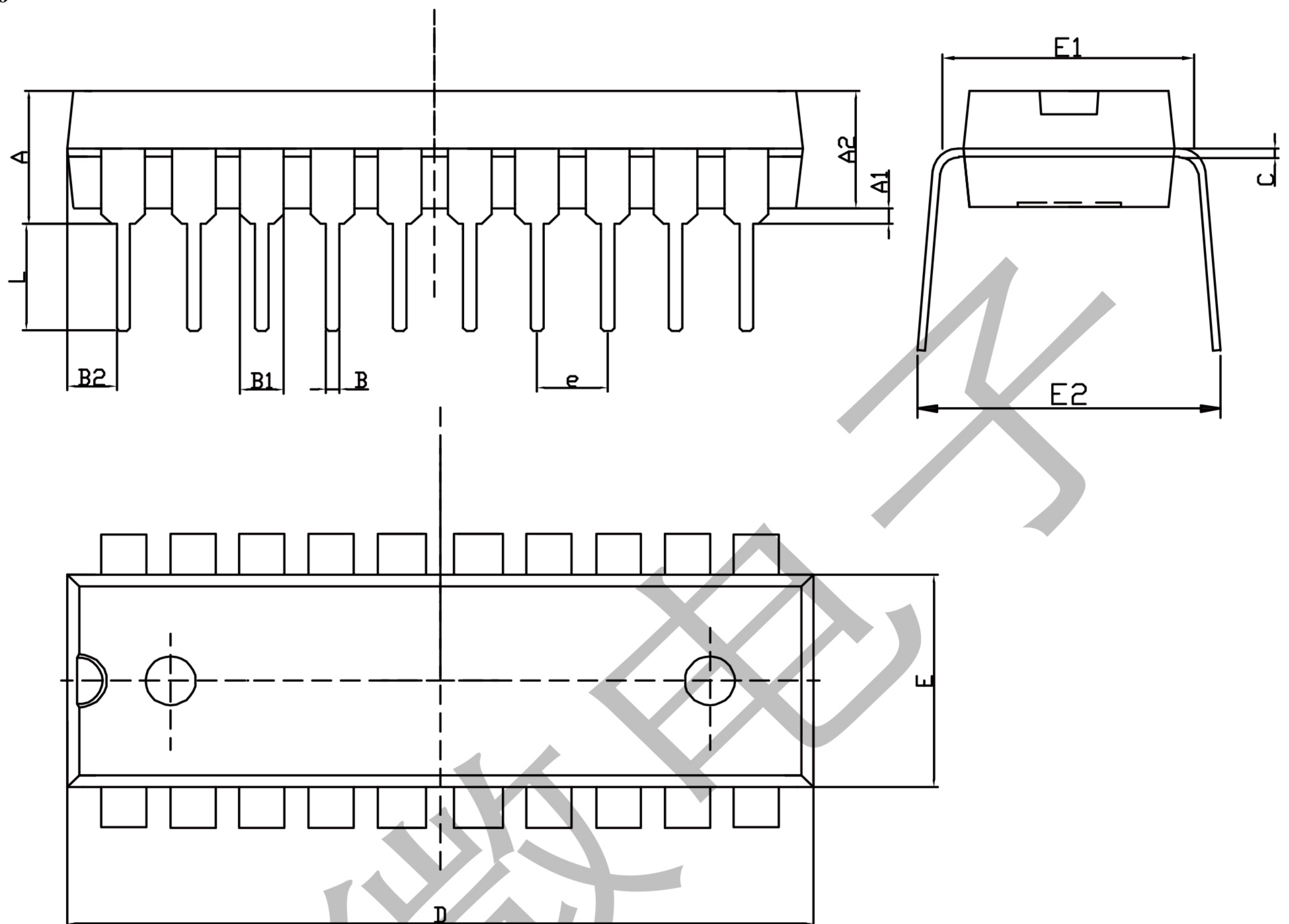

Symbol	Unit: mm		
	Minimum	Typical value	Maximum value
A	3.71	4.00	4.31
A1	0.50	0.60	0.80
A2	3.20	3.40	3.60
B	0.33	0.45	0.53
B1	1.525(TYP)		
C	0.20	0.28	0.36
D	25.70	26.00	26.54
E	6.20	6.40	6.75
E1	7.32	7.78	8.25
e	2.54(TYP)		
L	3.00	3.30	3.60
E2	8.20	8.70	9.10
B2	0.87	1.02	1.17

SOP20-300

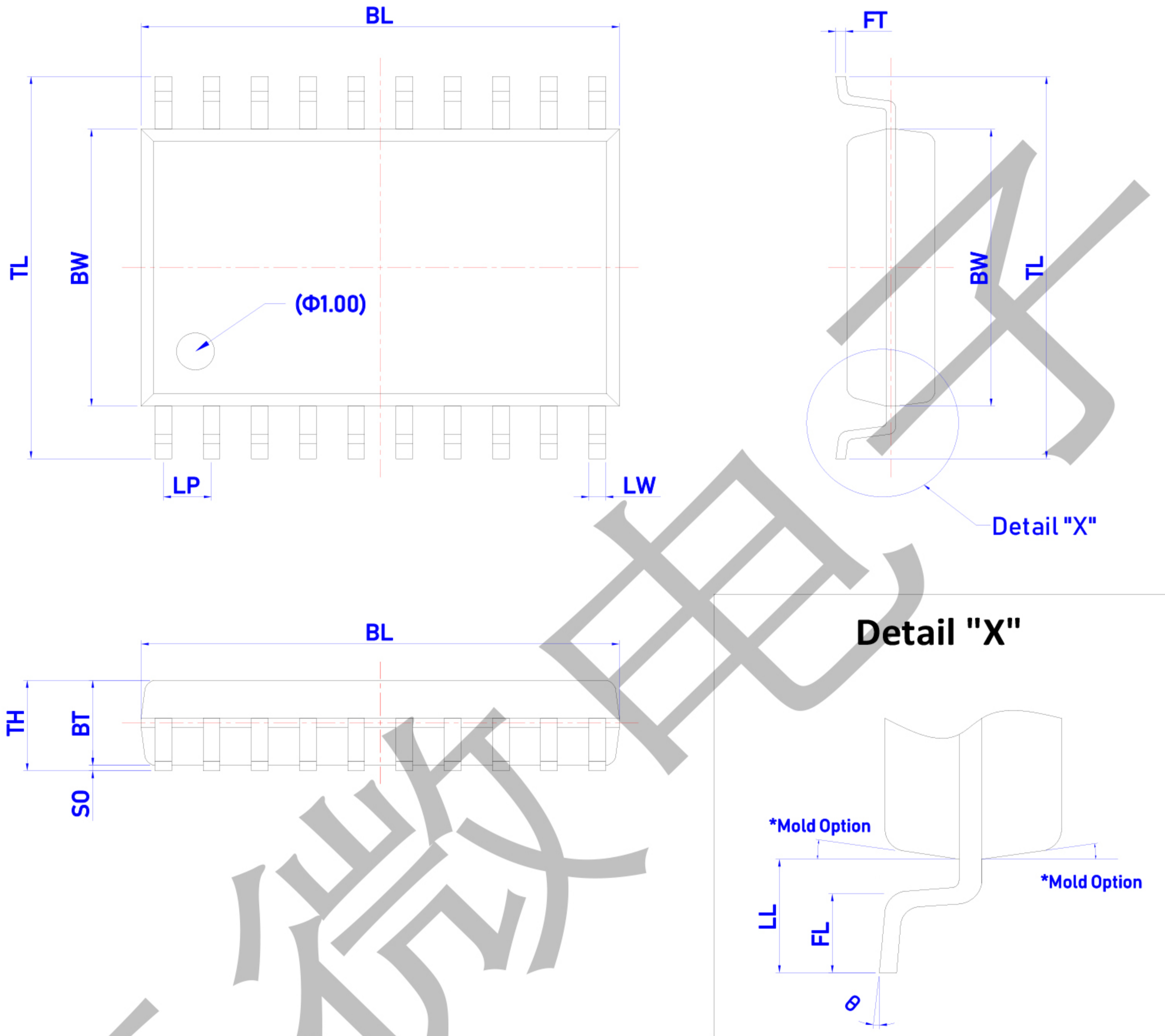

Dimensions

Item	BL	BW	TL	LW	LP	FT	BT	SO	TH	LL	FL	θ
表示	总长	胶体宽度	跨度	脚宽	脚间距	脚厚	胶体厚度	站高	胶体高度	单边长	脚长	脚角度
Unit	mm	mm	mm	mm	mm	mm	mm	mm	mm	mm	mm	°
Spec	12.70 (12.60) 12.50	7.55 (7.50) 7.45	10.50 (10.35) 10.20	0.440 TYP	1.270 TYP	0.300 (0.250) 0.200	2.40 (2.30) 2.20	0.250 (0.150) 0.100	2.550 Max.	1.50 (1.40) 1.30	0.90 (0.80) 0.70	8 (4) 0

All specs and applications shown above subject to change without prior notice.