

# WIZ550SR Datasheet

## Overview

This page provides information about the hardware description of WIZ550SR as following:

- Hardware Specification
- Electrical Characteristics
- Schematic
- Dimension

The revision history will be updated in this page in case of any changes of hardware specification or exterior design.

## Hardware Specification

### WIZ550SR

- Very small size Serial to Ethernet Module.
- WIZ.net TCP/IP Chip **W5500**.
- STM32F103RCT6.
- Not include a transformer and RJ45.
- 2.00mm Pitch Pin Header Type, 1×11.
- Support the **MDI**(Medium Dependent Interface).
  - TXN, TXP, RXN, RXP
- Support the **UART** interface.
  - RXD, TXD, RTS, CTS, DSR(Optional), DTR(Optional)
  - Support the RS-232C Interface.
  - Will be supported the RS-422/485 Interface.
- Support the Debug UART.
  - DEBUG RXD, DEBUG TXD
- Support the PHY Status Output.
  - Active LED, Link LED
- Support the STATUS output.
  - LOW : TCP Connect.
  - HIGH : TCP Disconnect.
- System Pins.
  - RESET : System Reset, Active Low.
  - BOOT0 : MCU BOOT mode operation, Active High.
  - H/W TRIG : App BOOT mode operation, Active Low.
- Support the Indicator LED.
  - Power LED(LD3).
  - LED 0(LD1) :
  - LED 1(LD2) :
- Support the Pin Header Hole for Firmware upload.
  - 2.54mm Pitch, Not Mount.
- Support the Pin Header Hole for SWD.
  - 1.27mm Pitch, Not Mount.
- Include eeprom for data storage.
- Operation Temperature : -40°C ~ 85°C
- Size : 22mm x 24mm x 13mm

### WIZ550SR Pin Out

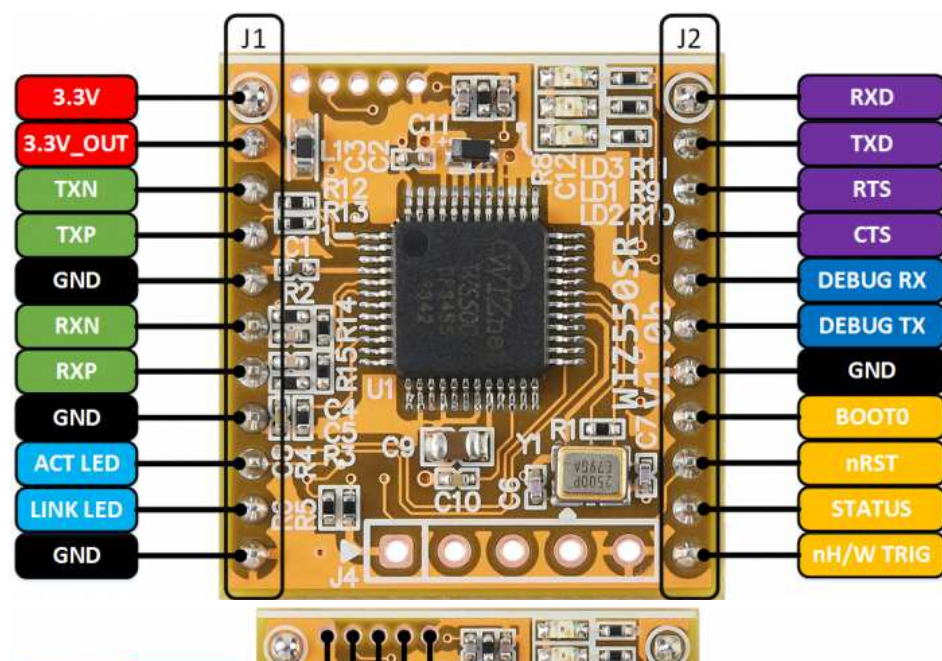

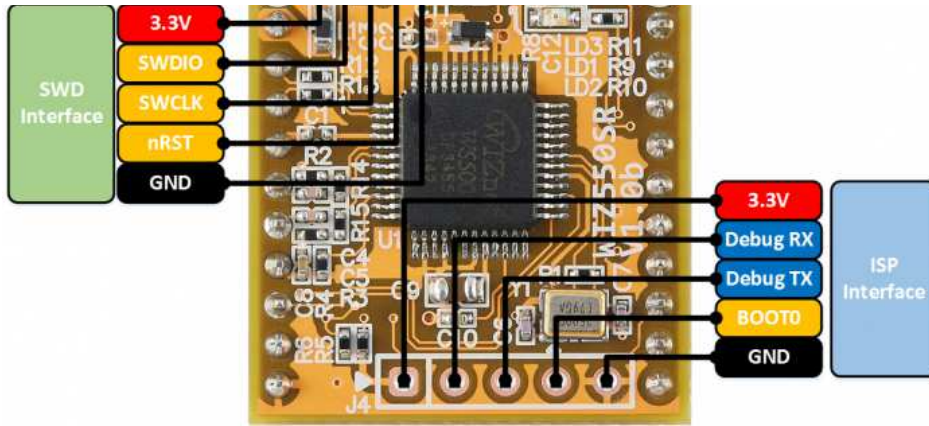

WIZ550SR Pin Description

Ref No.	Pin No.	Symbol	Type	Description
J1	1	3.3V	P	+3.3V Input Power
	2	3.3V_OUT	P	+3.3V Output Power. This pin is connected to the TX resistor of MDI signal and Center TAP of RJ45.
	3	TXN	O	MDI Signal. TX Positive.
	4	TXP	O	MDI Signal. TX Negative.
	5	GND	P	Ground.
	6	RXN	I	MDI Signal. RX Negative.
	7	RXP	I	MDI Signal. RX Positive.
	8	GND	P	Ground.
	9	ACT LED	O	PHY Active LED
	10	LINK LED	O	PHY Link LED
	11	GND	P	Ground.

Ref No.	Pin No.	Symbol	Type	Description
J2	1	RXD	I	Data UART. Recieve Pin.
	2	TXD	O	Data UART. Transmit Pin.
	3	RTS	O	Data UART. Request to Send Pin.
	4	CTS	I	Data UART. Clear to Send Pin.
	5	DEBUG_RX	I	Debug UART. Recieve Pin.
	6	DEBUG_TX	O	Debug UART. Transmit Pin.
	7	GND	P	Ground.
	8	BOOT0	I	MCU Boot. Active High
	9	nRST	I	Reset. Active Low
	10	STATUS	O	Status Output. High : Disconnect. Low : Connect.
	11	nH/W TRIG	I	App Boot. Hardware TRIG Input. Active Low

WIZ550SR Block Diagram

## WIZ550SR Block Diagram

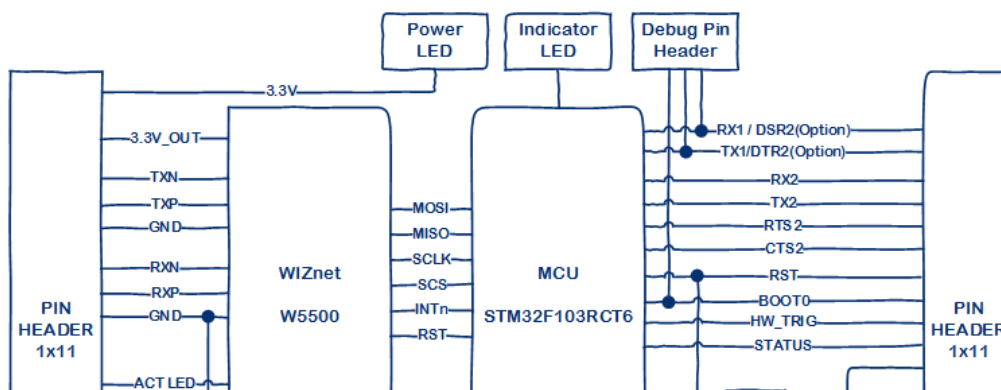

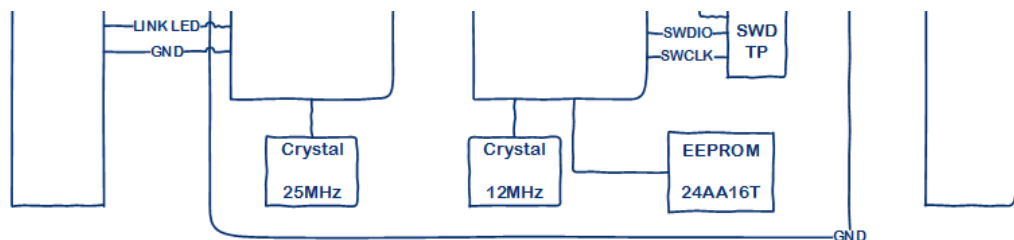

WIZ550SR EVB

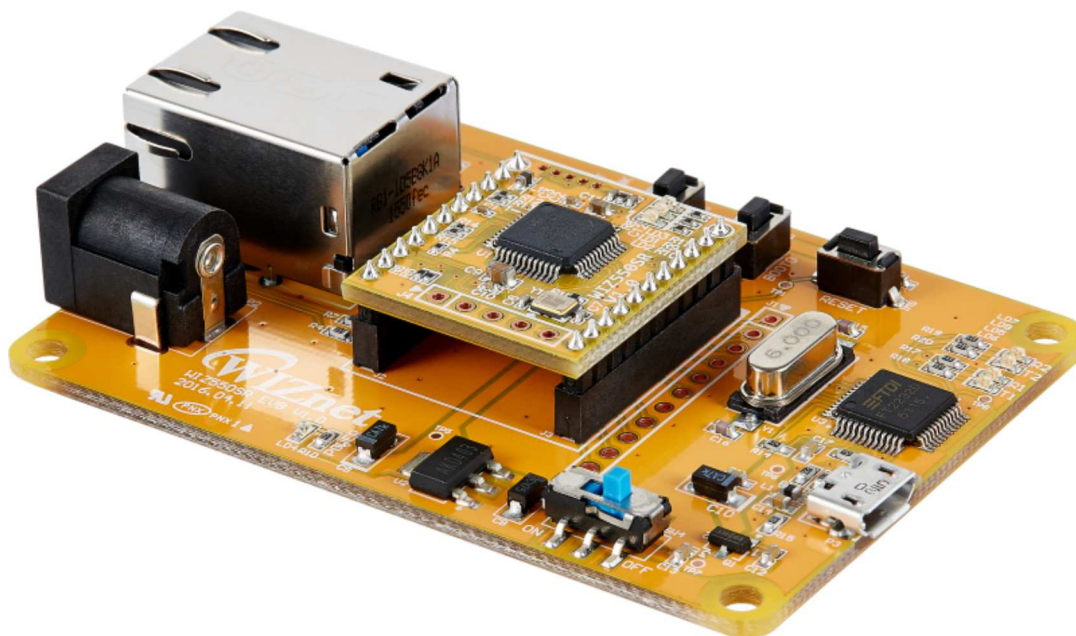

- WIZ550SR Developer Board.
- USB to UART chip, FT2232D.
- RJ45 with Transformer, RB1-1D5B8K1A.
- RESET Tact SW.
- BOOT0 Tact SW.
- H/W Trig Tact SW.
- LED Indicators.
- Micro USB.

WIZ550SR EVB Call Out

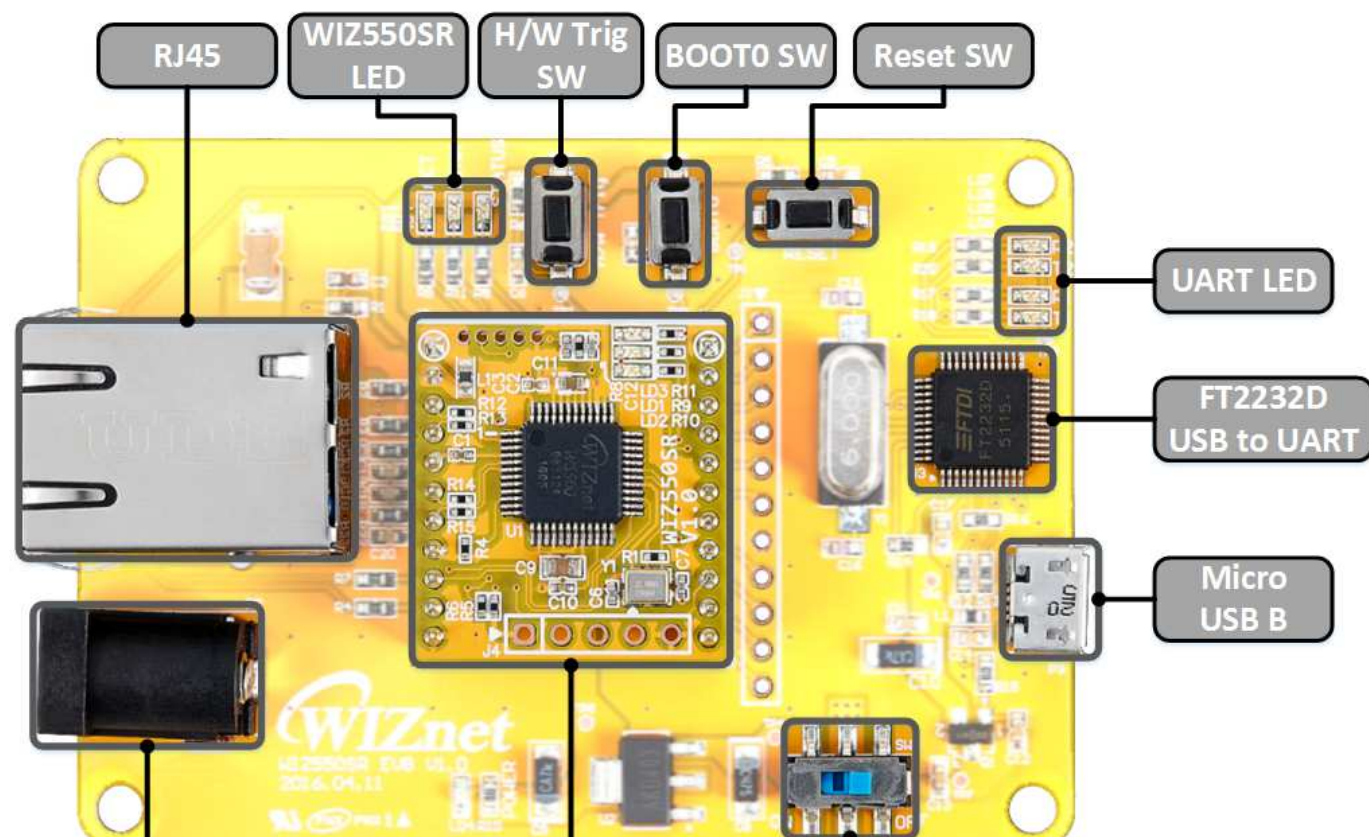

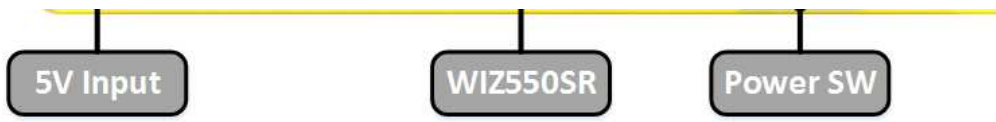

WIZ550SR EVB Block Diagram

## WIZ550SR EVB Block Diagram

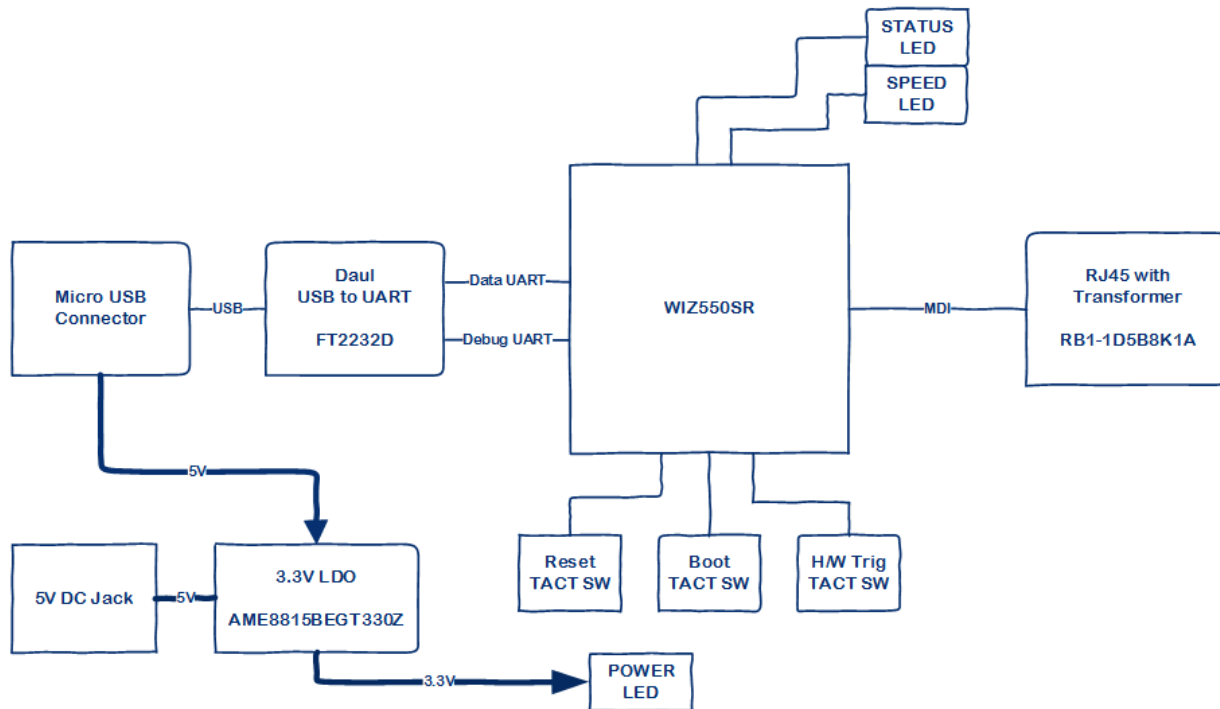

### Electrical Characteristics

#### Operating conditions at power-up / power-down

Symbol	Parameter	Conditions	Min	Max	Unit
TVDD	VDD rise time rate	-	0	-	us/V
	VDD fall time rate	-	20	-	

#### DC Characteristics

Symbol	Parameter	Pins	Min	Typ	Max	Unit
VDD	Supply voltage	3.3V	2.97	3.3	3.6	V
VIL	High level input voltage	ALL	1.833		3.6	V
VIH	Low level input voltage	ALL	-0.3		1.166	V
VOL	Low level output voltage	ALL			0.4	V
VOH	High level output voltage	ALL	3.0			V
LOL	Low level input Current Sink Current	ALL			-25	mA
LOH	High level output Current Source Current	ALL			25	mA
IDD	Supply Current (Normal operation mode)	3.3V		TBD		mA

#### nRST pin Characteristics

Symbol	Parameter	Conditions	Min	Typ	Max	Unit
VIL(nRST)	NRST Input low level voltage	-	-0.5	-	0.8	V
VIH(nRST)	NRST Input high level voltage	-	-2	-	3.8V	V
Vhys(nRST)	NRST Schmitt trigger voltage hysteresis	-	-	200	-	mV
RPU	Weak pull-up equivalent resistor	-	30	40	50	kΩ
VF(nRST)	NRST Input filtered pulse	-	-	-	100	ns
VNF(nRST)	NRST Input not filtered pulse	-	300	-	-	ns

### Power Dissipation

Condition	Min	Typ	Max	Unit
100M Link	-	180	-	mA
10M Link	-	TBD	-	mA
Un-Link (Auto-negotiation mode)	-	TBD	-	mA
100M Transmitting	-	TBD	-	mA
10M Transmitting	-	TBD	-	mA
Power Down mode	-	TBD	-	mA

### Schematics & BOM

#### Ref. Schematic

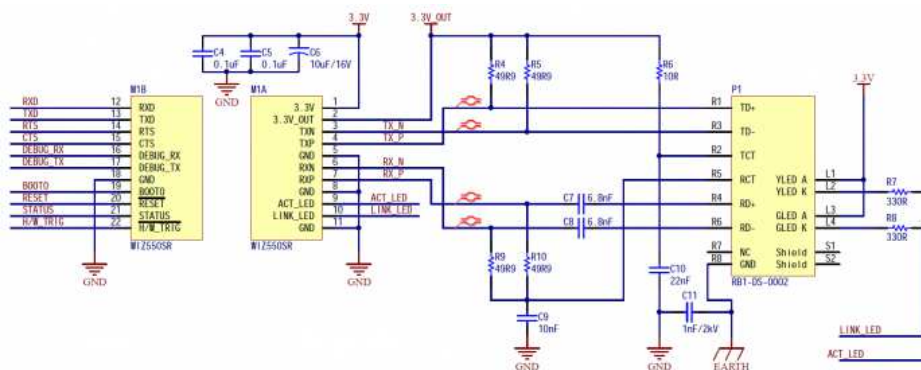

- [WIZ550SR Ref Schematic : Download](#)

#### WIZ550SR Schematic

- [WIZ550SR V1.0 Schematic : Download\(Altium\)](#)
- [WIZ550SR V1.0 Schematic : Download\(PDF\)](#)

#### WIZ550SR BOM

- [WIZ550SR V1.0 BOM: Download](#)

#### WIZ550SR EVB Schematic

- [WIZ550SR EVB V1.0 Schematic : Download\(Altium\)](#)
- [WIZ550SR EVB V1.0 Schematic : Download\(PDF\)](#)

#### WIZ550SR EVB BOM

- [WIZ550SR EVB V1.0 BOM : Download](#)

### Dimension

- [WIZ550SR V1.0 3D PDF : Download](#)
- This PDF must be run using the 'Adobe Acrobat'.

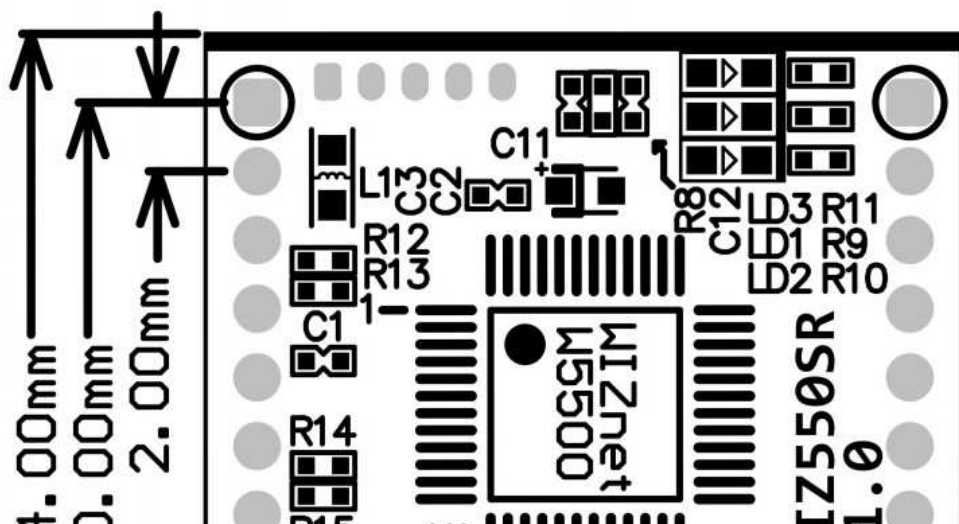

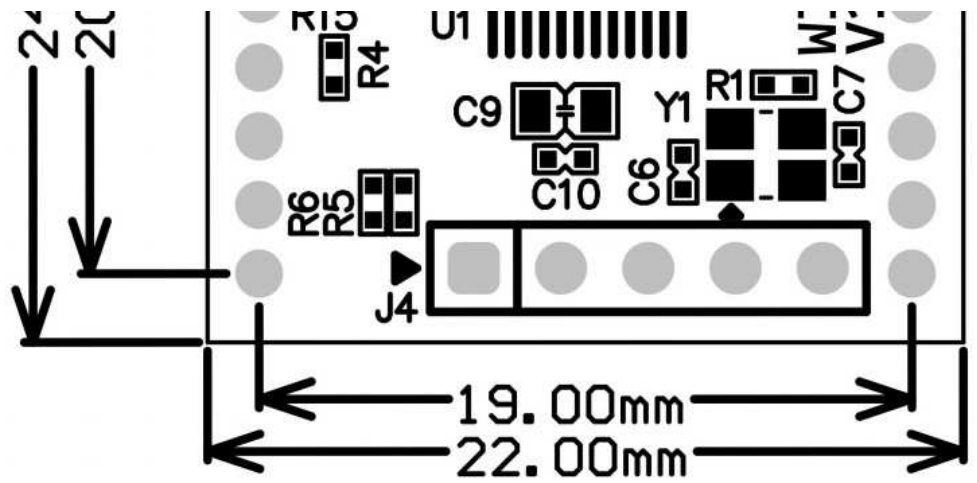

See Also