



DC Input 8-Pin Phototransistor Optocoupler

Features

- High isolation 5000 VRMS
- DC input with transistor output
- Operating temperature range - 55 °C to 110 °C
- External Creepage $\geq 7.5\text{mm}$ (S/SL Type)
- External Creepage $\geq 8.0\text{mm}$ (SLM Type)
- RoHS compliant
- REACH compliance
- Green material
- Regulatory Approvals
 - UL - UL1577 (E364000)
 - VDE - EN60747-5-5(VDE0884-5)
 - CQC – GB4943.1, GB8898
 - IEC60065, IEC60950

Description

The CT827 series consists of dual channels each contains a photo transistor optically coupled to a gallium arsenide Infrared-emitting diode in a 8-lead DIP package different lead forming options.

Applications

- Switch mode power supplies
- Computer peripheral interface
- Microprocessor system interface

Package Outline

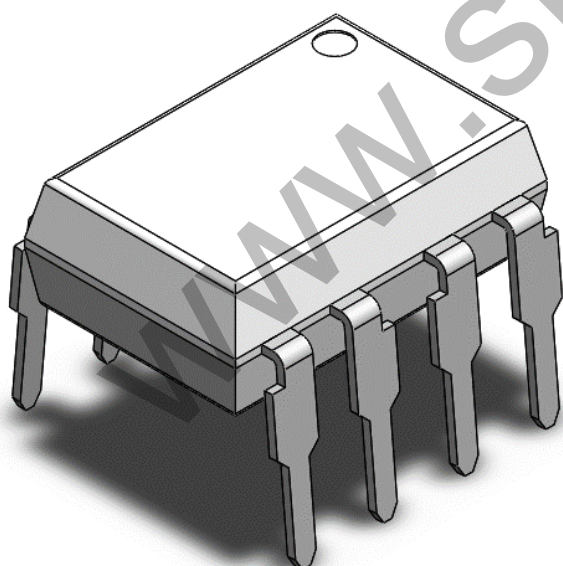

Note: Different lead forming options available. See package dimension.

Schematic

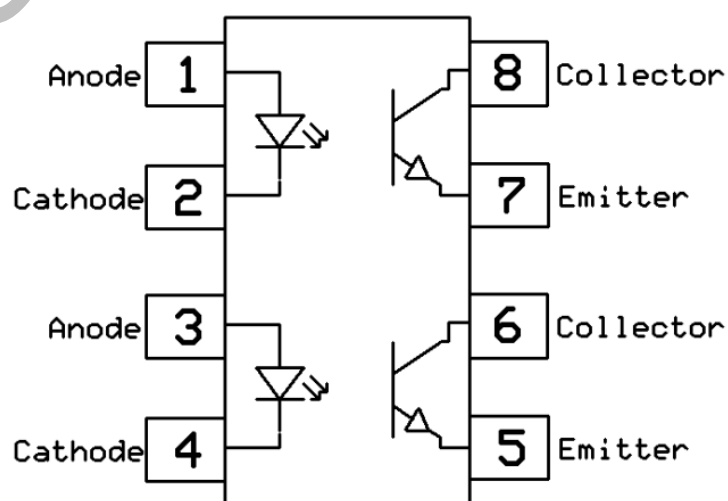

**Absolute Maximum Rating at 25°C**

Symbol	Parameters	Ratings	Units	Notes
V _{ISO}	Isolation voltage	5000	V _{RMS}	
P _{TOT}	Total power dissipation	200	mW	
T _{OPR}	Operating temperature	-55 ~ +110	°C	
T _{STG}	Storage temperature	-55 ~ +150	°C	
T _{SOL}	Soldering temperature	260	°C	
Emitter (1 circuit)				
I _F	Forward current	60	mA	
I _{F(TRANS)}	Peak transient current (≤1μs P.W,300pps)	1	A	
V _R	Reverse voltage	6	V	
P _D	Emitter power dissipation	100	mW	
Detector (1 circuit)				
P _D	Detector power dissipation	150	mW	
B _{VCEO}	Collector-Emitter Breakdown Voltage	80	V	
B _{VECO}	Emitter-Collector Breakdown Voltage	7	V	
I _C	Collector Current	50	mA	

**Electrical Characteristics** $T_A = 25^\circ\text{C}$ (unless otherwise specified)**Emitter Characteristics**

Symbol	Parameters	Test Conditions	Min	Typ	Max	Units	Notes
V_F	Forward voltage	$I_F = 10\text{mA}$		1.24	1.4	V	
I_R	Reverse Current	$V_R = 6\text{V}$	-	-	5	μA	
C_{IN}	Input Capacitance	$f = 1\text{MHz}$	-	10	30	pF	

Detector Characteristics

Symbol	Parameters	Test Conditions	Min	Typ	Max	Units	Notes
$B_{V_{CEO}}$	Collector-Emitter Breakdown	$I_C = 100\mu\text{A}$	80	-	-	V	
$B_{V_{ECO}}$	Emitter-Collector Breakdown	$I_E = 100\mu\text{A}$	7	-	-	V	
I_{CEO}	Collector-Emitter Dark Current	$V_{CE} = 20\text{V}, I_F = 0\text{mA}$	-	-	100	nA	

Transfer Characteristics

Symbol	Parameters	Test Conditions	Min	Typ	Max	Units	Notes
CTR	Current Transfer Ratio	CT827	50		600	%	
		CT827A	80		160		
		CT827B	130		260		
$V_{CE(SAT)}$	Collector-Emitter Saturation Voltage	$I_F = 20\text{mA}, I_C = 1\text{mA}$	-	0.1	0.2	V	
R_{IO}	Isolation Resistance	$V_{IO} = 500\text{V}_{DC}$	5×10^{10}			Ω	
C_{IO}	Isolation Capacitance	$f = 1\text{MHz}$		0.5	1	pF	

Switching Characteristics

Symbol	Parameters	Test Conditions	Min	Typ	Max	Units	Notes
t_r	Rise Time	$I_C = 2\text{mA}, V_{CE} = 2\text{V}$	-	6	18	μs	
t_f	Fall Time	$R_L = 100\Omega$	-	8	18		



Typical Characteristic Curves

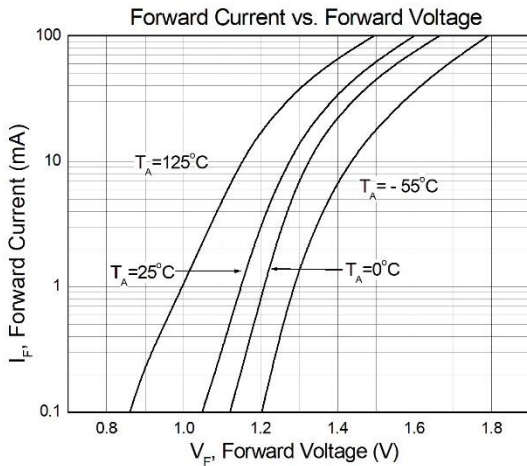

Figure 2

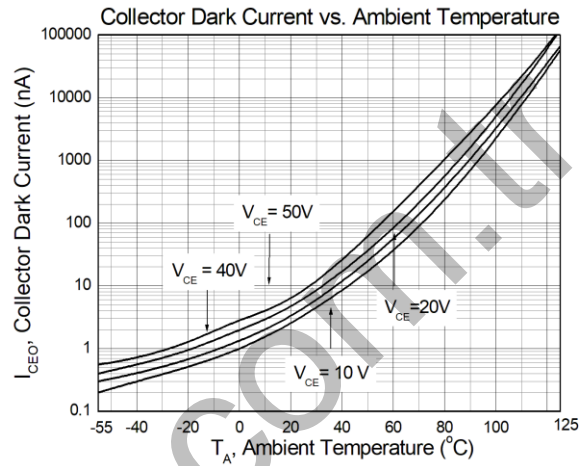

Figure 3

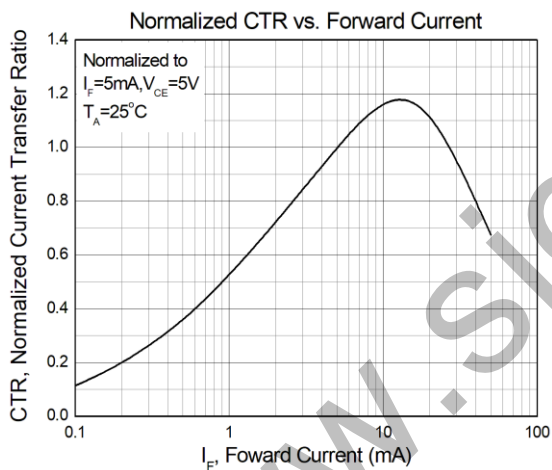

Figure 4

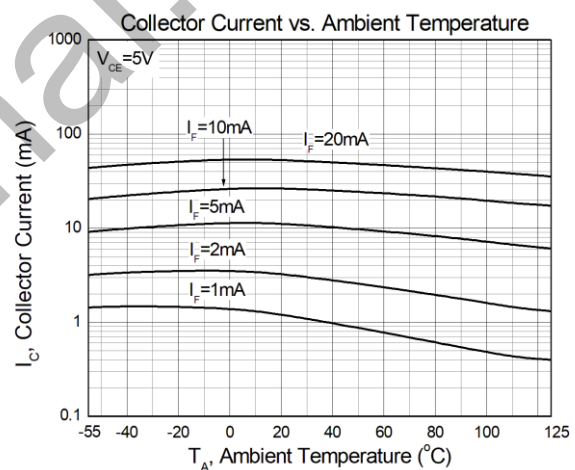

Figure 5

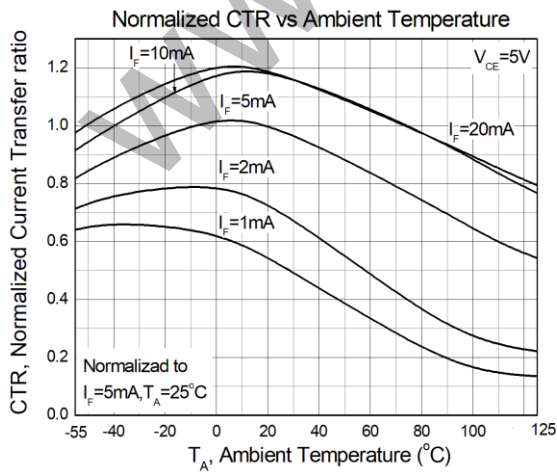

Figure 6

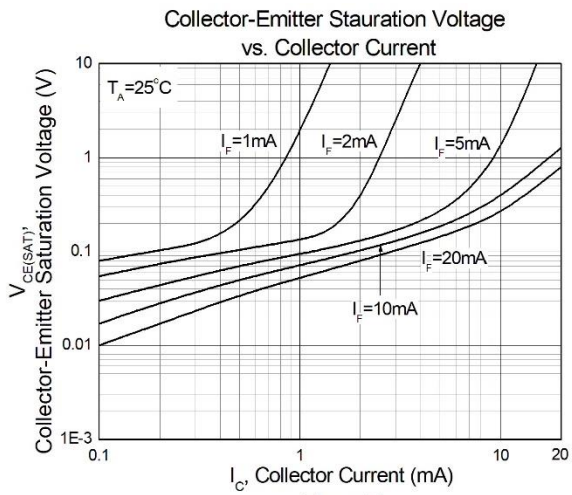

Figure 7



Collector-Emitter Saturation Voltage vs. Forward Current

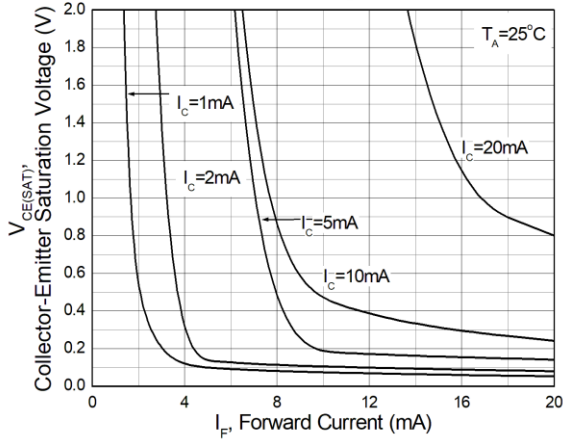

Figure 8

Switching Speed vs. Load Resistance

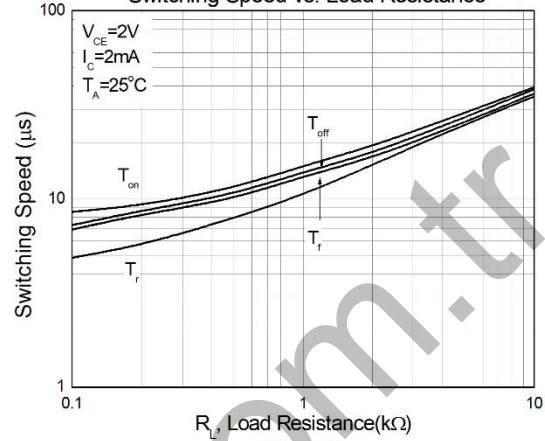

Figure 9

Voltage Gain vs. Frequency

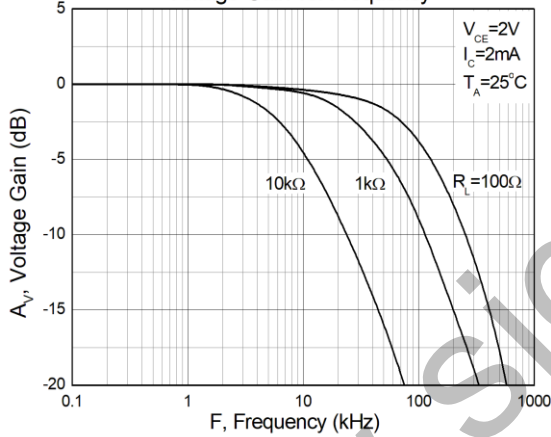

Figure 10



Test Circuit

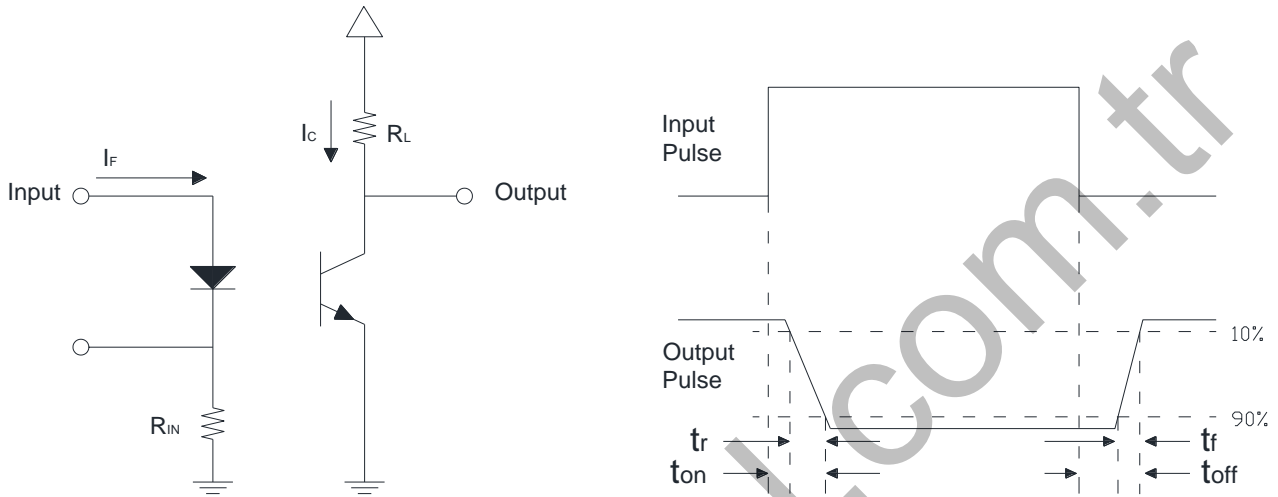
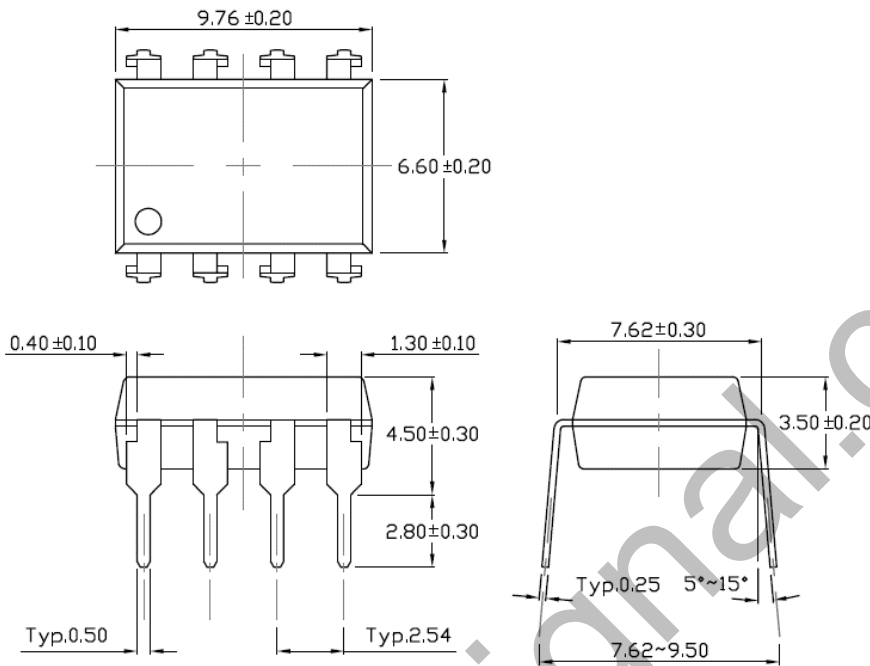

Figure 12: Switching Time Test Circuits



Package Dimension *Dimensions in mm unless otherwise stated*

Standard DIP – Through Hole



Gullwing (400mil) Lead Forming – Through Hole (M Type)

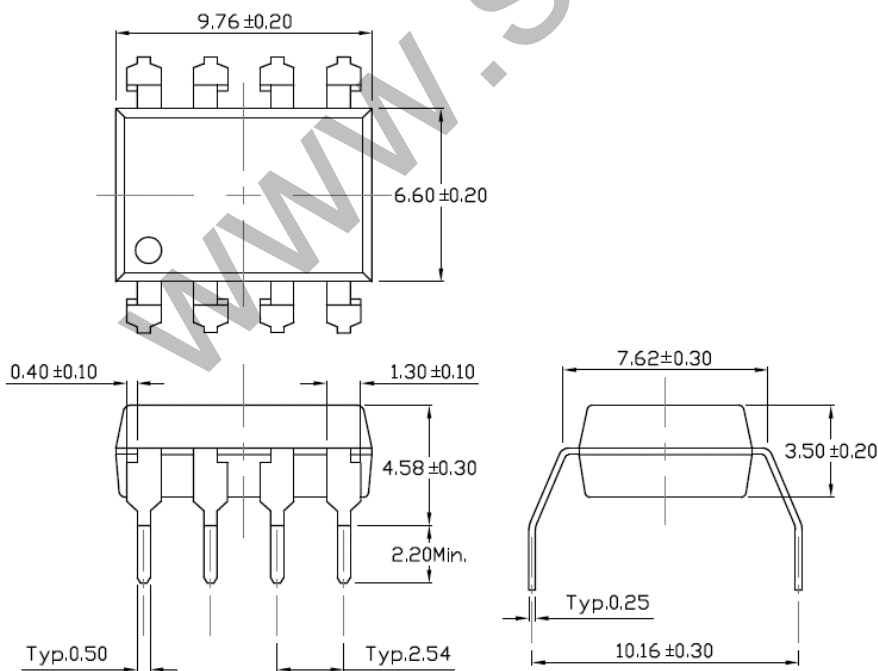



Surface Mount Lead Forming (S Type)

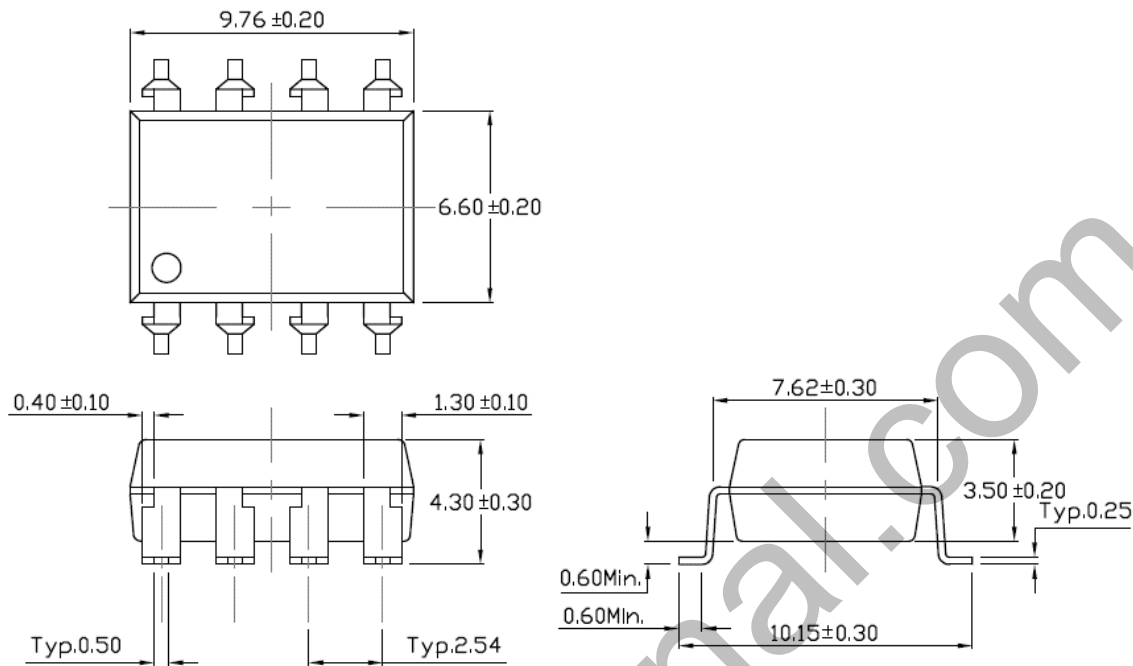

Surface Mount (Low Profile) Lead Forming (SL Type)

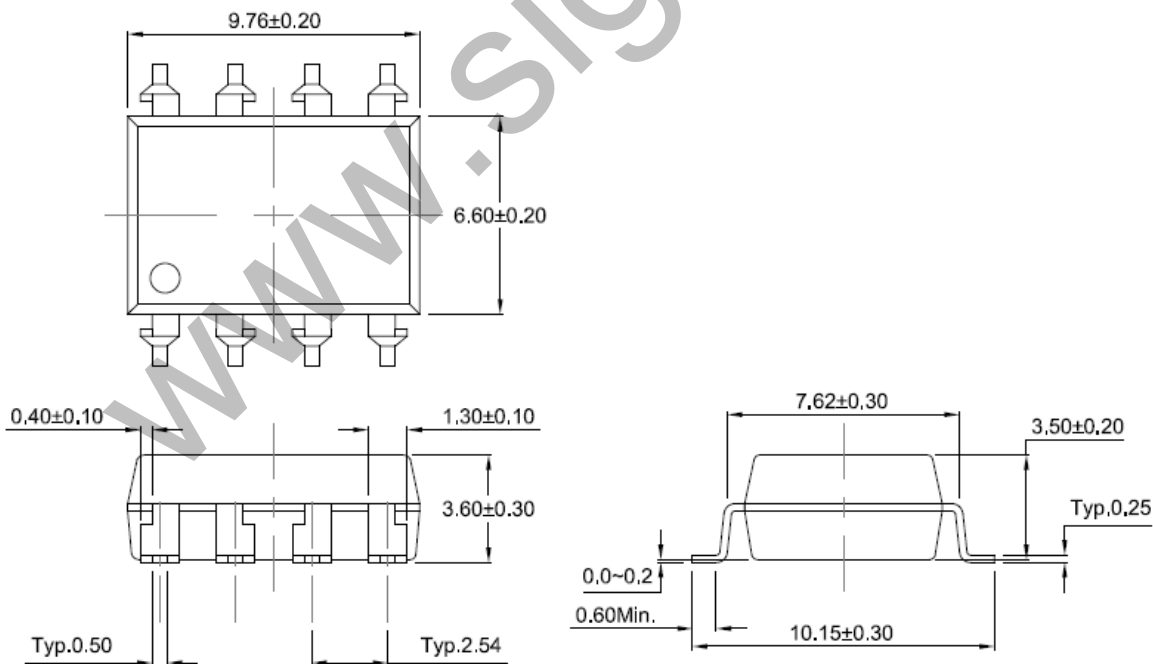



Recommended Solder Mask *Dimensions in mm unless otherwise stated*

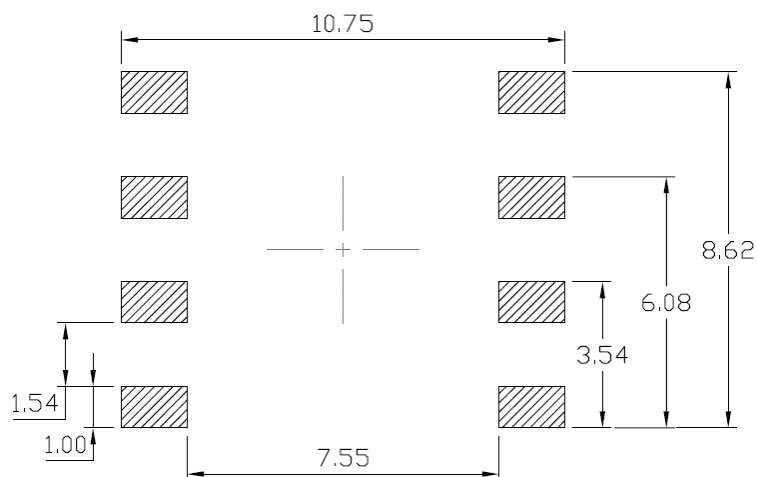

Device Marking

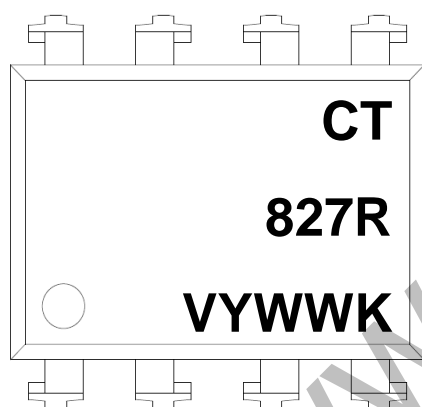

Note:

- CT : Denotes "CT Micro"
- 827 : Product Number
- R : CTR Rank
- V : VDE Option
- Y : Fiscal Year
- WW : Work Week
- K : Production Code

**Ordering Information****CT827X(V)(Y)(Z)**

CT =Denotes “CT Micro”

827 =Product Number

X = Part No. (X=A, B or None)

V = VDE Option (V or None)

Y = Lead form option (S, SL, M or none)

Z = Tape and reel option (T1, T2 or none)

Option	Description	Quantity
None	Standard 8 Pin Dip	40 Units/Tube
M	Gullwing (400mil) Lead Forming	40 Units/Tube
S(T1)	Surface Mount Lead Forming – With Option 1 Taping	1000 Units/Reel
S(T2)	Surface Mount Lead Forming – With Option 2 Taping	1000 Units/Reel
SL(T1)	Surface Mount (Low Profile) Lead Forming– With Option 1 Taping	1000 Units/Reel
SL(T2)	Surface Mount (Low Profile) Lead Forming– With Option 2 Taping	1000 Units/Reel



Carrier Tape Specifications *Dimensions in mm unless otherwise stated*

Option S(T1) & SL(T1)

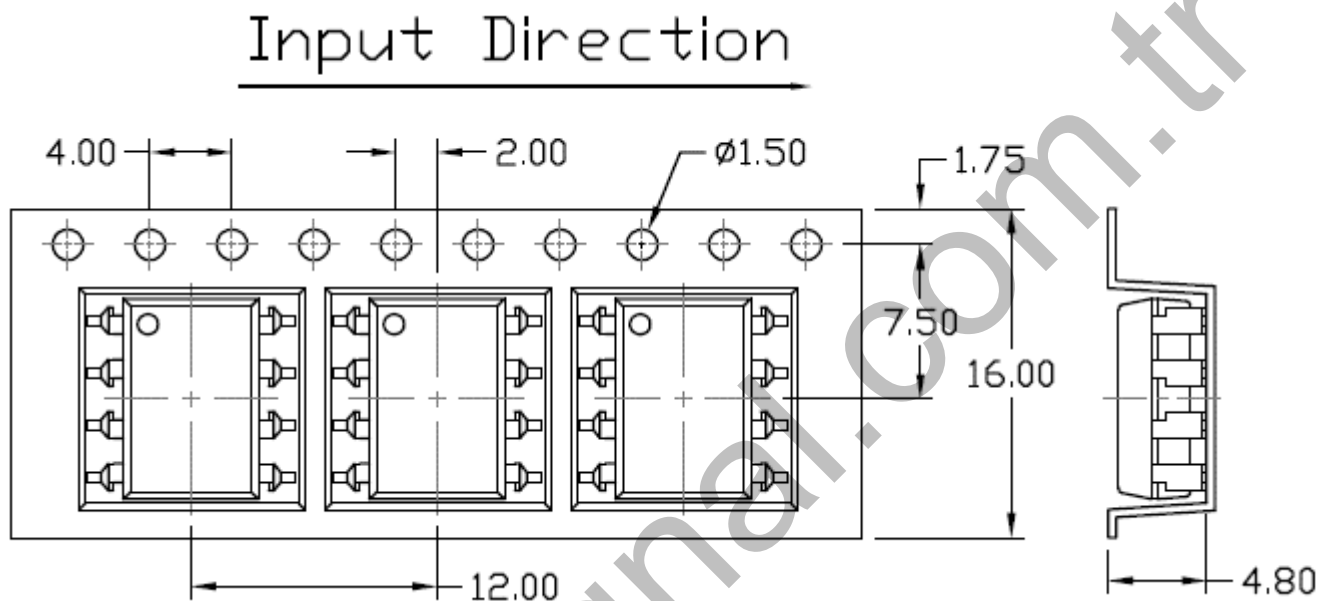

Option S(T2) & SL(T2)

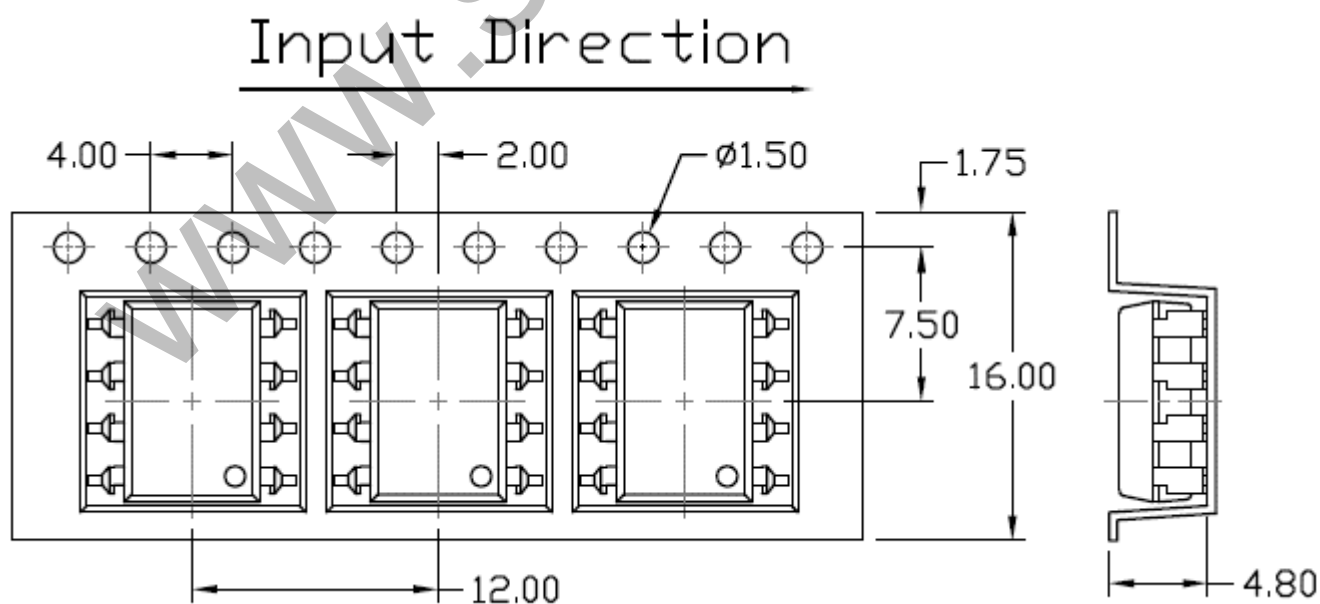



Wave soldering (follow the JEDEC standard JESD22-A111)

One time soldering is recommended within the condition of temperature.

Temperature: $260 \pm 5^\circ\text{C}$.

Time: 10 sec.

Preheat temperature: 25 to 140°C .

Preheat time: 30 to 80 sec.

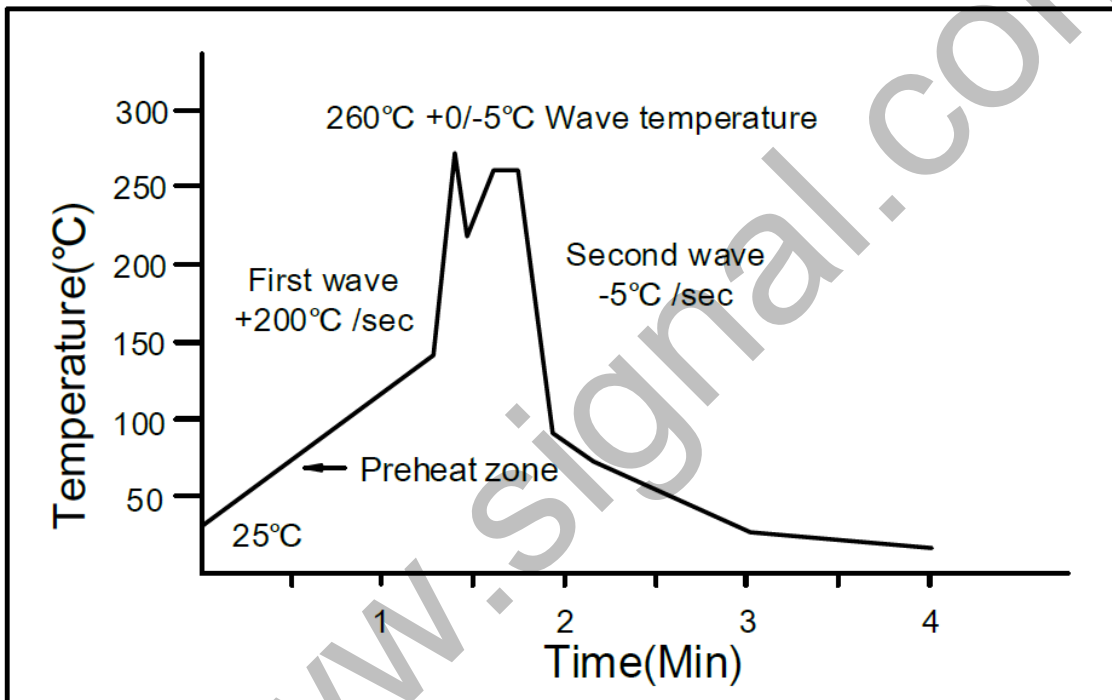

Hand soldering by soldering iron

Allow single lead soldering in every single process.

One time soldering is recommended. Temperature: $380 \pm 5^\circ\text{C}$

Time: 3 sec max.



Reflow Profile

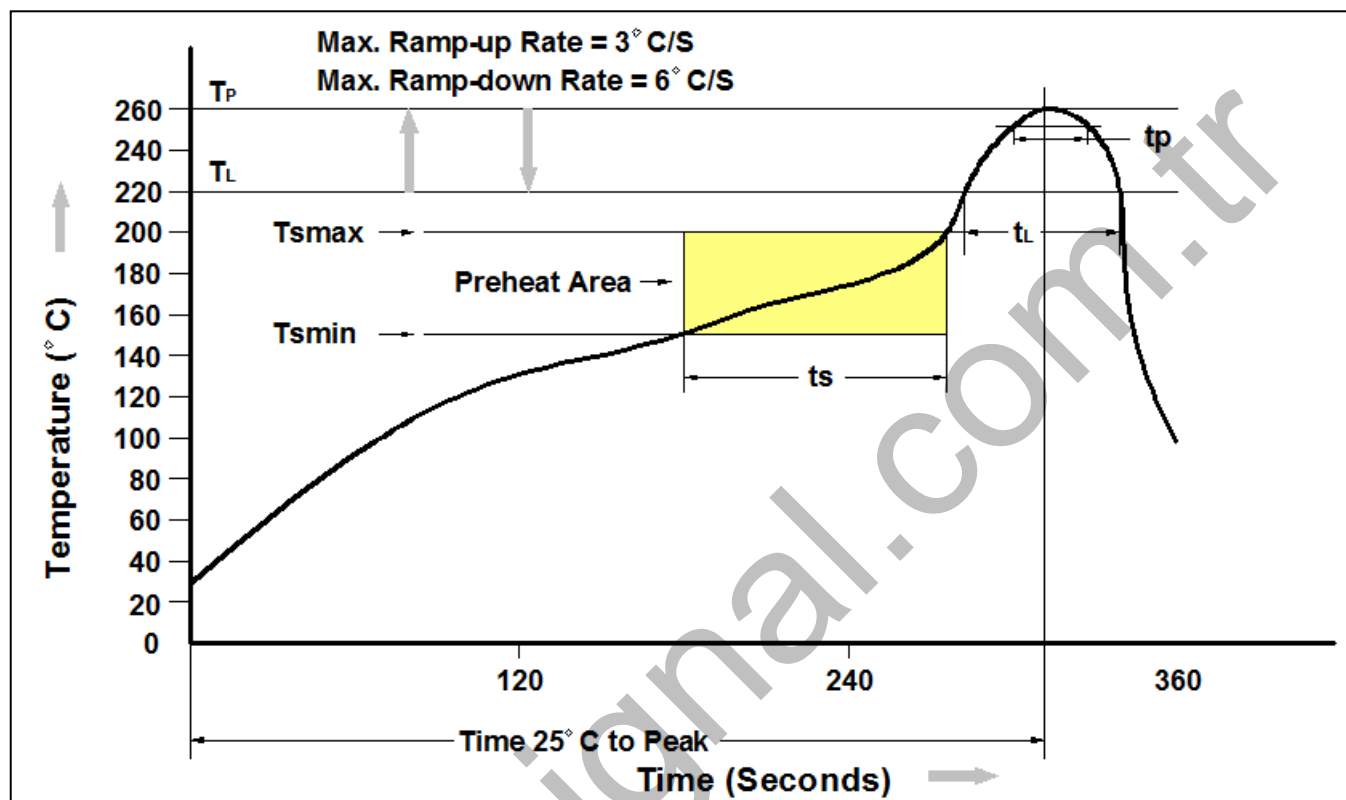

Profile Feature	Pb-Free Assembly Profile
Temperature Min. (Tsmin)	150°C
Temperature Max. (Tsmax)	200°C
Time (ts) from (Tsmin to Tsmax)	60-120 seconds
Ramp-up Rate (tl to tp)	3°C/second max.
Liquidous Temperature (TL)	217°C
Time (tl) Maintained Above (TL)	60 – 150 seconds
Peak Body Package Temperature	260°C +0°C / -5°C
Time (tp) within 5°C of 260°C	30 seconds
Ramp-down Rate (TP to TL)	6°C/second max
Time 25°C to Peak Temperature	8 minutes max.



DISCLAIMER

CT MICRO RESERVES THE RIGHT TO MAKE CHANGES WITHOUT FURTHER NOTICE TO ANY PRODUCTS HEREIN TO IMPROVE RELIABILITY, FUNCTION OR DESIGN. CT MICRO DOES NOT ASSUME ANY LIABILITY ARISING OUT OF THE APPLICATION OR USE OF ANY PRODUCT OR CIRCUIT DESCRIBED HEREIN; NEITHER DOES IT CONVEY ANY LICENSE UNDER ITS PATENT RIGHTS, NOR THE RIGHTS OF OTHERS.

DISCOLORATION MIGHT OCCUR ON THE PACKAGE SURFACE AFTER SOLDERING, REFLOW OR LONG TERM USE. THIS DOES NOT IMPACT THE PRODUCT PERFORMANCE NOR THE PRODUCT RELIABILITY.

CT MICRO ARE NOT AUTHORIZED FOR USE AS CRITICAL COMPONENTS IN LIFE SUPPORT DEVICES OR SYSTEMS WITHOUT EXPRESS WRITTEN APPROVAL OF CT MICRO INTERNATIONAL CORPORATION.

- 1. Life support devices or systems are devices or systems which, (a) are intended for surgical implant into the body, or (b) support or sustain life, or (c) whose failure to perform when properly used in accordance with instruction for use provided in the labelling, can be reasonably expected to result in significant injury to the user.*
- 2. A critical component is any component of a life support device or system whose failure to perform can be reasonably expected to cause the failure of the life support device or system, or to affect its safety or effectiveness.*