



## AC Input 4-Pin Phototransistor Optocoupler

### Features

- High isolation 5000 VRMS
- CTR flexibility available see order information
- DC input with transistor output
- External Creepage  $\geq 7.5\text{mm}$  (S/SL Type)
- External Creepage  $\geq 8.0\text{mm}$  (SLM Type)
- Operating Temperature range - 55 °C to 110 °C
- Regulatory Approvals
  - UL - UL1577 (E364000)
  - VDE - EN60747-5-5(VDE0884-5)
  - CQC – GB4943.1, GB8898
  - IEC60065, IEC60950

### Description

The CT814 series consists of a phototransistor optically coupled to two gallium arsenide Infrared-emitting diode, connected in inverse parallel, in a 4-lead DIP package with bending options.

### Applications

- Switch mode power supplies
- Computer peripheral interface
- Microprocessor system interface

### Package Outline

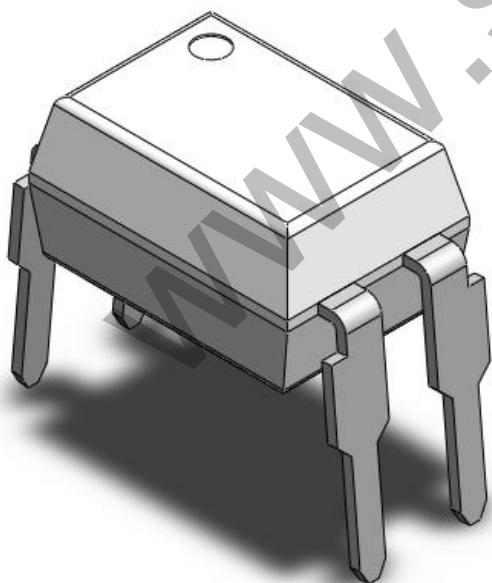

### Schematic

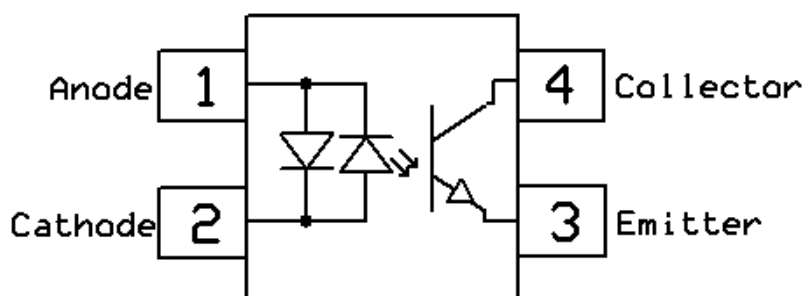

**Absolute Maximum Rating at 25°C**

<b>Symbol</b>	<b>Parameters</b>	<b>Ratings</b>	<b>Units</b>	<b>Notes</b>
V <sub>ISO</sub>	Isolation voltage	5000	V <sub>RMS</sub>	
P <sub>TOT</sub>	Total power dissipation	200	mW	
T <sub>OPR</sub>	Operating temperature	-55 ~ +110	°C	
T <sub>STG</sub>	Storage temperature	-55 ~ +150	°C	
T <sub>SOL</sub>	Soldering temperature	260	°C	
<b>Emitter</b>				
I <sub>F</sub>	Forward current	±60	mA	
I <sub>F(TRANS)</sub>	Peak transient current (≤1μs P.W,300pps)	1	A	
P <sub>D</sub>	Emitter power dissipation	100	mW	
<b>Detector</b>				
P <sub>D</sub>	Detector power dissipation	150	mW	
B <sub>VCEO</sub>	Collector-Emitter Breakdown Voltage	80	V	
B <sub>VECO</sub>	Emitter-Collector Breakdown Voltage	6	V	
I <sub>C</sub>	Collector Current	50	mA	



## AC Input 4-Pin Phototransistor Optocoupler

### Electrical Characteristics $T_A = 25^\circ\text{C}$ (unless otherwise specified)

#### Emitter Characteristics

Symbol	Parameters	Test Conditions	Min	Typ	Max	Units	Notes
$V_F$	Forward voltage	$I_F = \pm 10\text{mA}$	-	1.24	1.4	V	
$C_{IN}$	Input Capacitance	$f = 1\text{MHz}$	-	30	-	pF	

#### Detector Characteristics

Symbol	Parameters	Test Conditions	Min	Typ	Max	Units	Notes
$B_{V_{CEO}}$	Collector-Emitter Breakdown	$I_C = 100\mu\text{A}$	80	-	-	V	
$B_{V_{ECO}}$	Emitter-Collector Breakdown	$I_E = 100\mu\text{A}$	6	-	-	V	
$I_{CEO}$	Collector-Emitter Dark Current	$V_{CE} = 20\text{V}, I_F = 0\text{mA}$	-	-	100	nA	

#### Transfer Characteristics

Symbol	Parameters	Test Conditions	Min	Typ	Max	Units	Notes	
CTR	Current Transfer Ratio	$I_F = \pm 1\text{mA}, V_{CE} = 5\text{V}$	CT814	20	-	300	%	
			CT814A	50	-	150		
			CT814B	100	-	300		
	CTR Symmetry	$I_F = \pm 1\text{mA}, V_{CE} = 5\text{V}$	0.7	-	1.3			
$V_{CE(SAT)}$	Collector-Emitter Saturation Voltage	$I_F = \pm 20\text{mA}, I_C = 1\text{mA}$	-	0.04	0.2	V		
$R_{IO}$	Isolation Resistance	$V_{IO} = 500\text{V}_{DC}$	$5 \times 10^{10}$	-	-	$\Omega$		
$C_{IO}$	Isolation Capacitance	$f = 1\text{MHz}$	-	0.5	1	pF		

#### Switching Characteristics

Symbol	Parameters	Test Conditions	Min	Typ	Max	Units	Notes
$t_r$	Rise Time	$I_C = 2\text{mA}, V_{CE} = 2\text{V}, R_L = 100\Omega$	-	6	-	$\mu\text{s}$	
$t_f$	Fall Time		-	8	-		



Typical Characteristic Curves

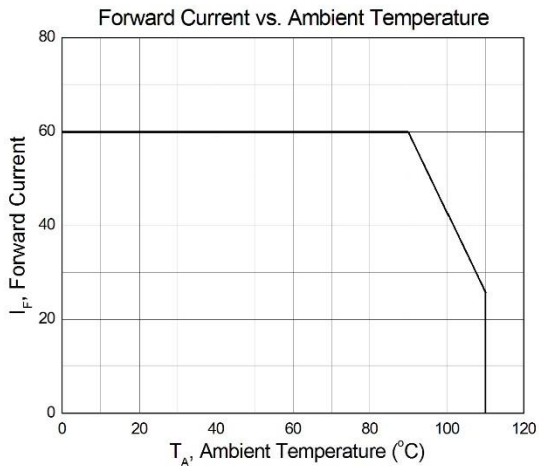

Figure 1

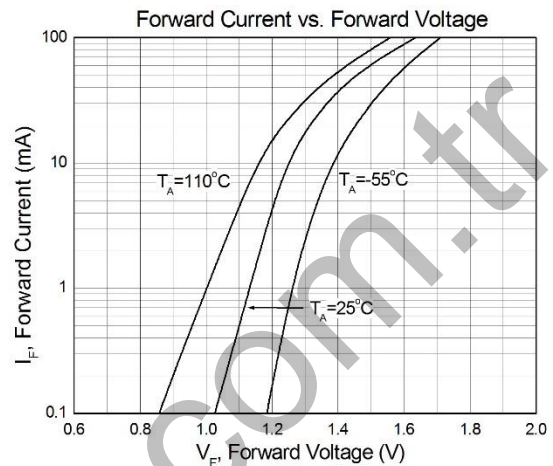

Figure 2

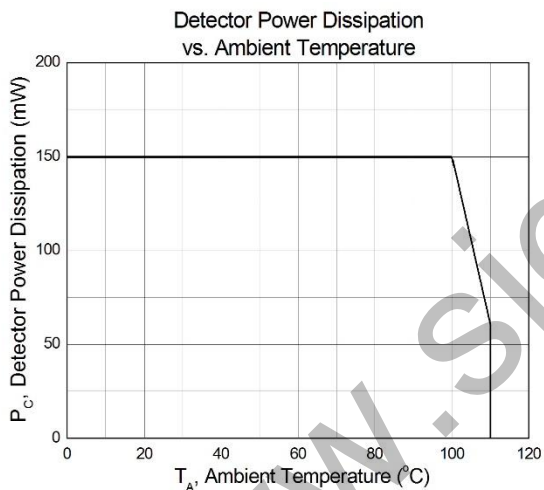

Figure 3

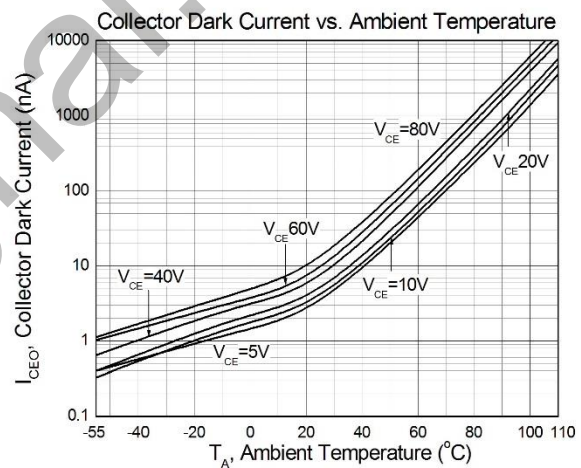

Figure 4

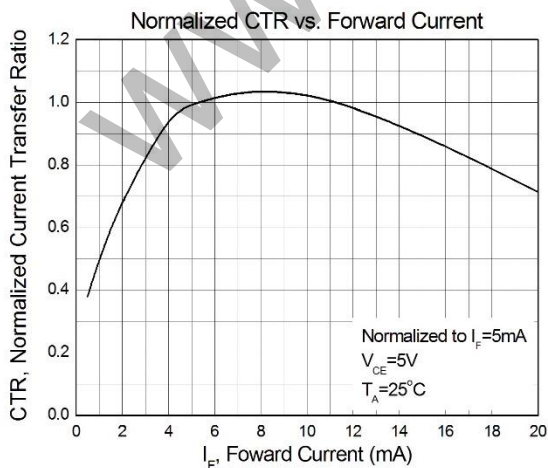

Figure 5

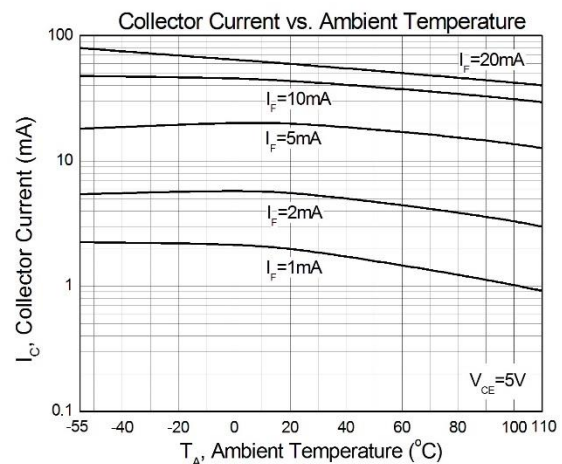

Figure 6

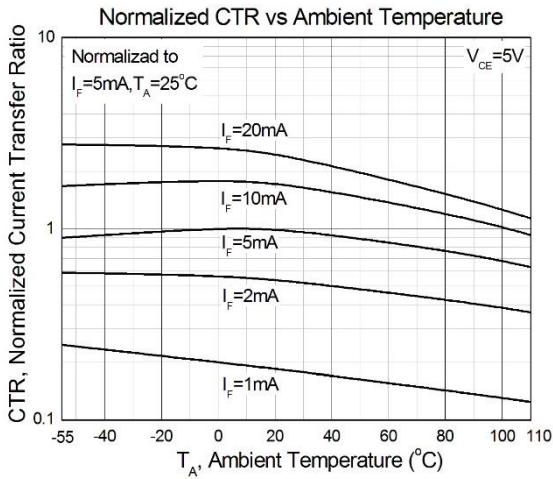

Figure 7

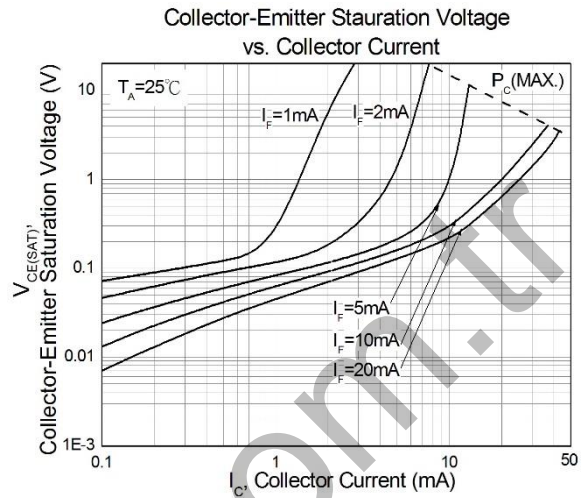

Figure 8

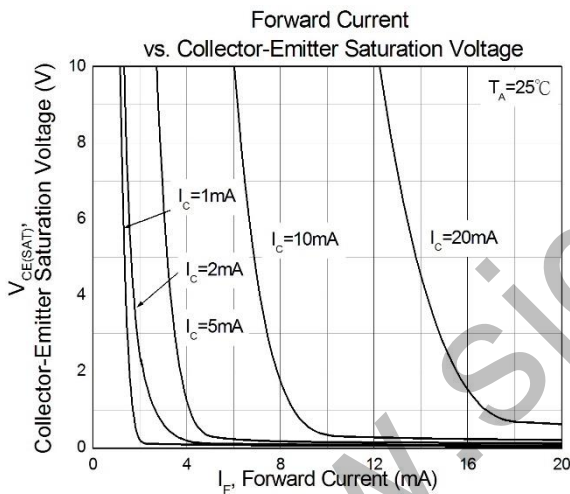

Figure 9

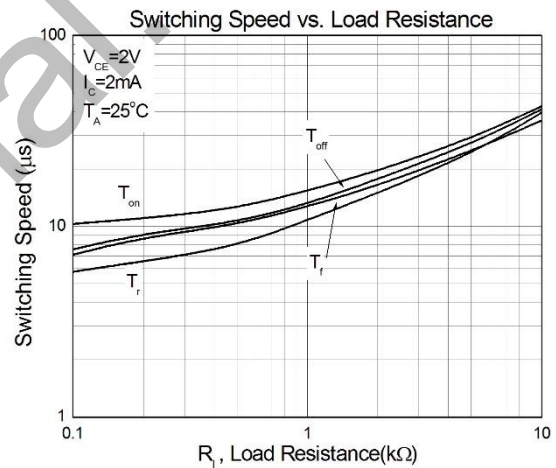

Figure 10

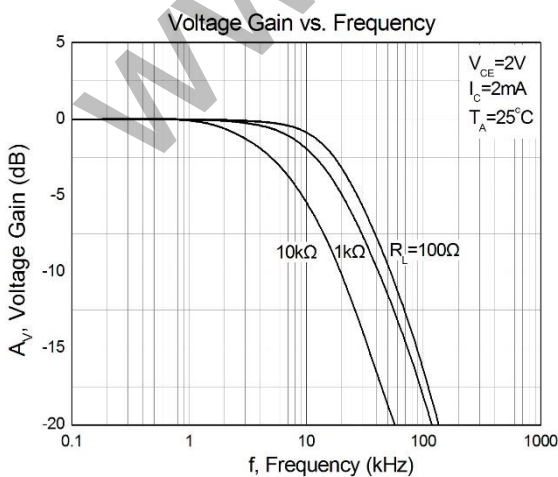
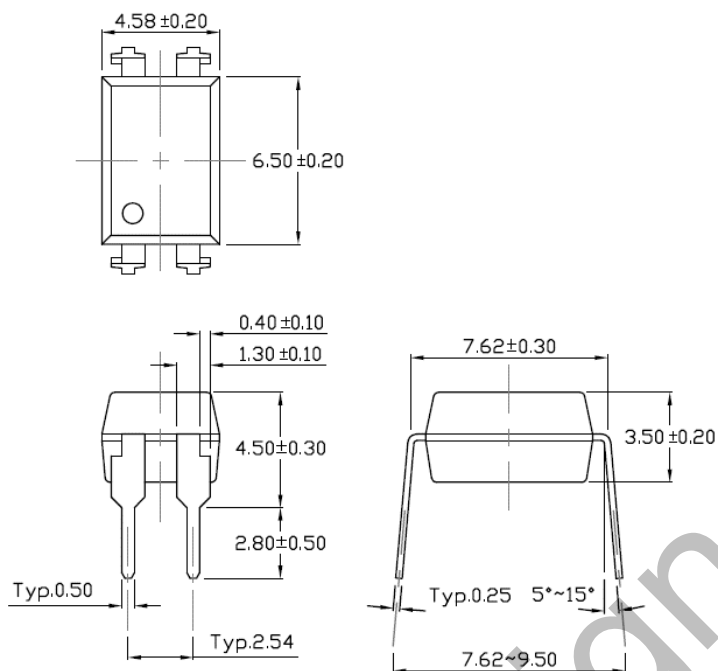

Figure 11



**Package Dimension** *Dimensions in mm unless otherwise stated*

**Standard DIP – Through Hole**



**Gullwing (400mil) Lead Forming – Through Hole (M Type)**

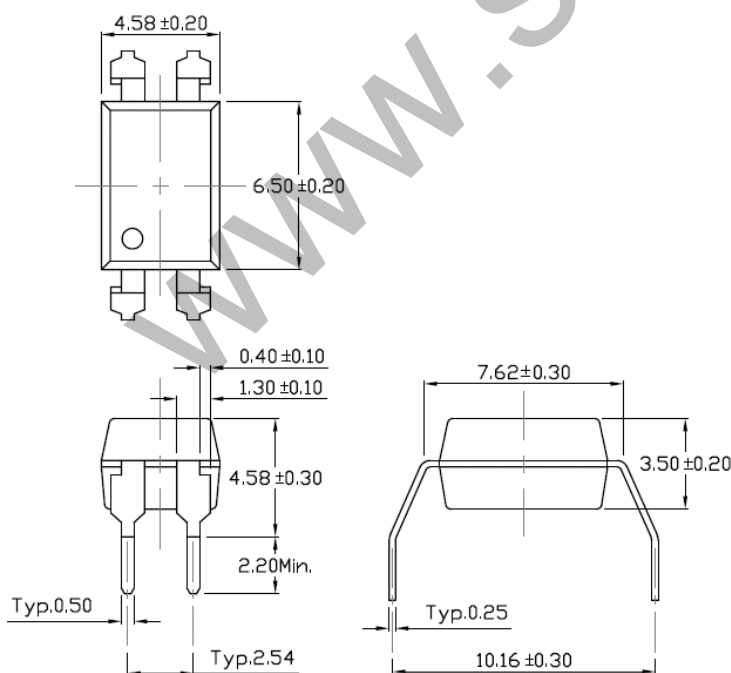



Surface Mount Lead Forming (S Type)

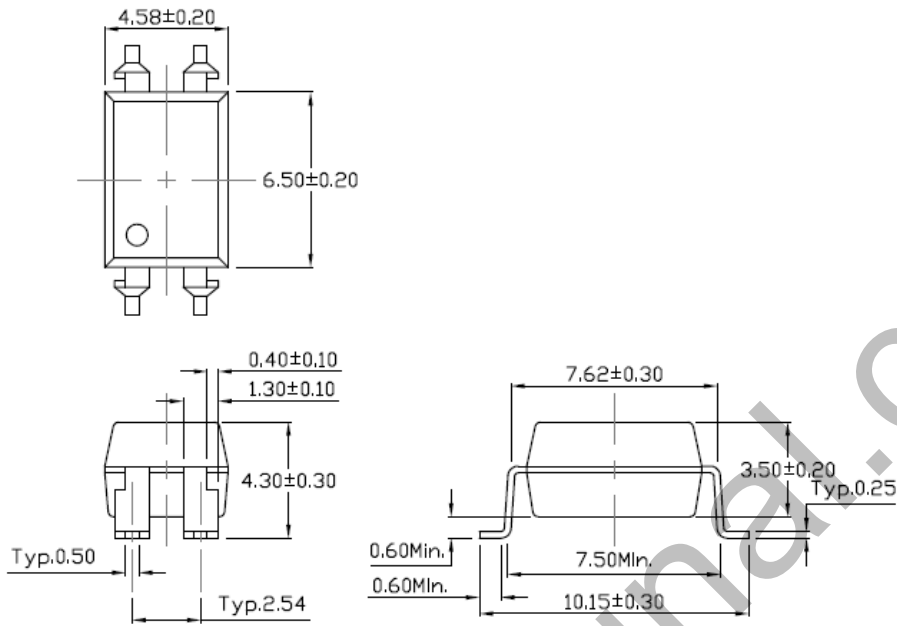

Surface Mount (Low Profile) Lead Forming (SL Type)

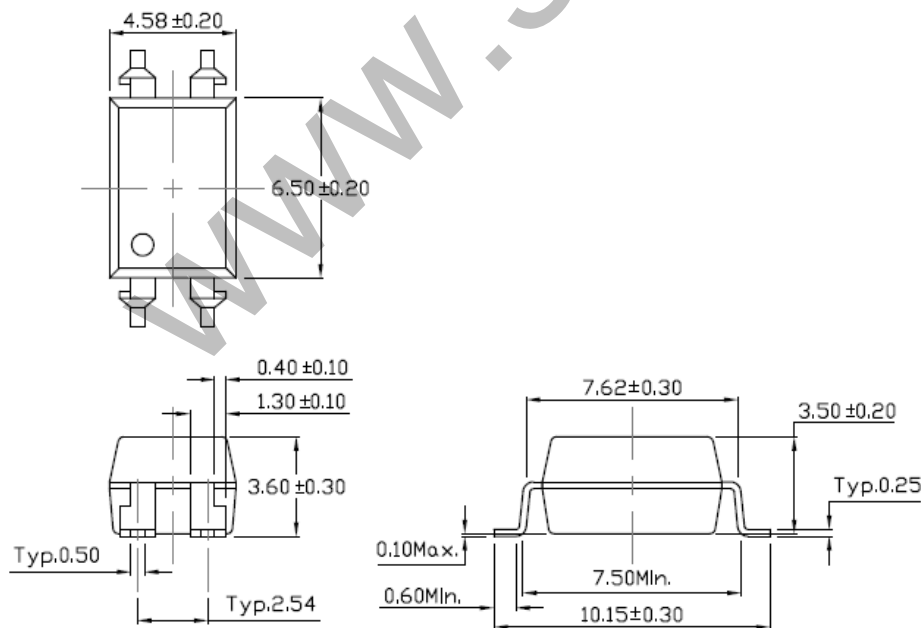



Surface Mount (Gullwing) Lead Forming (SLM Type)

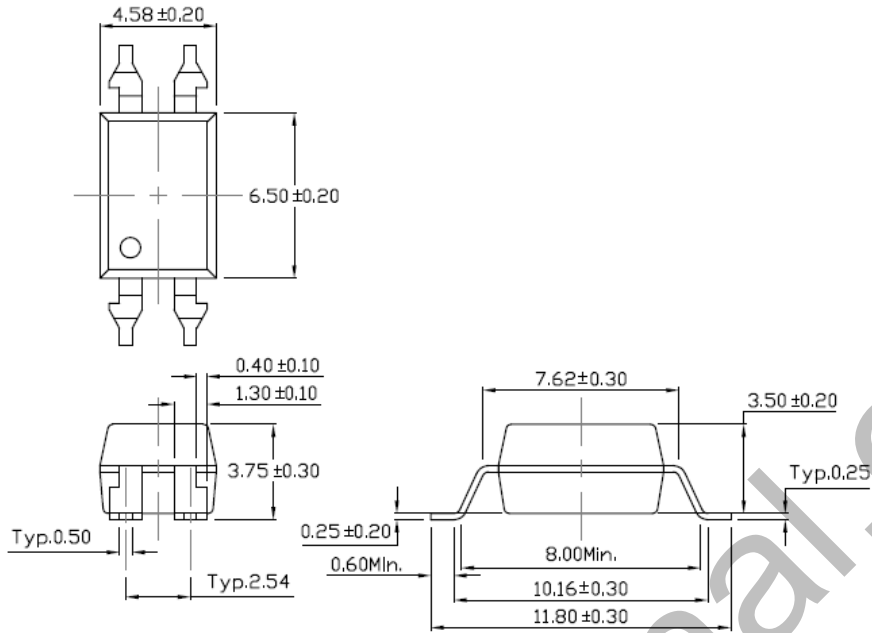



**Recommended Solder Mask** *Dimensions in mm unless otherwise stated*

**Surface Mount Lead Forming & Surface Mount (Low Profile) Lead Forming**

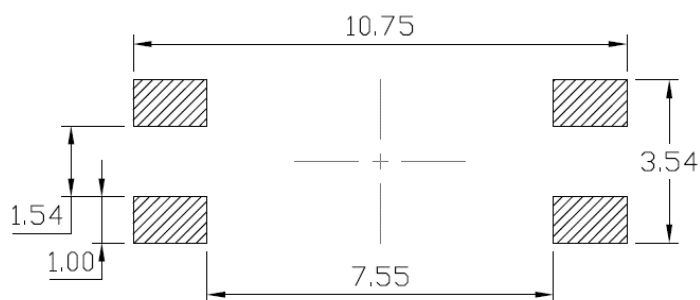

**Surface Mount (Gullwing) Lead Forming**

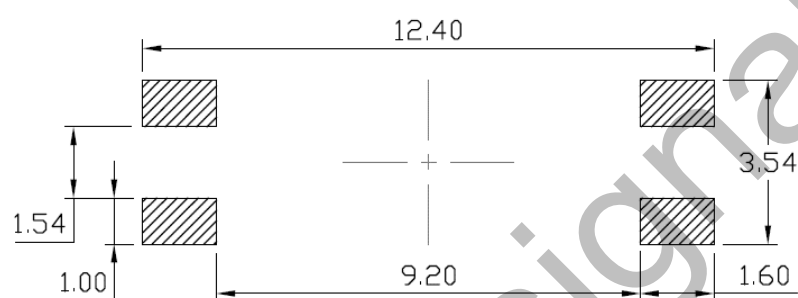

**Marking Information**

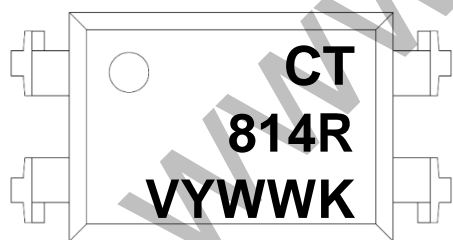

**Note:**

- CT : Denotes "CT Micro"
- 814 : Part Number
- R : CTR Rank
- V : VDE Option
- Y : Fiscal Year
- WW : Work Week
- K : Manufacturing Code

**Ordering Information****CT814X(V)(Y)(Z)-G**

X = Part No. (X=A, B or None)

V = VDE Option ( V or None)

Y = Lead form option (S, SL, M, SLM or none)

Z = Tape and reel option (T1, T2, T3, T4 or none)

G= Material option (G: Green, None: Non-green)

<b>Option</b>	<b>Description</b>	<b>Quantity</b>
None	Standard 4 Pin DIP	100 Units/Tube
M	Gullwing (400mil) Lead Forming	100 Units/Tube
S(T1)	Surface Mount Lead Forming – With Option 1 Taping	1500 Units/Reel
S(T2)	Surface Mount Lead Forming – With Option 2 Taping	1500 Units/Reel
S(T3)	Surface Mount Lead Forming – With Option 3 Taping	1000 Units/Reel
S(T4)	Surface Mount Lead Forming – With Option 4 Taping	1000 Units/Reel
SL(T1)	Surface Mount (Low Profile) Lead Forming– With Option 1 Taping	1500 Units/Reel
SL(T2)	Surface Mount (Low Profile) Lead Forming – With Option 2 Taping	1500 Units/Reel
SL(T3)	Surface Mount (Low Profile) Lead Forming– With Option 3 Taping	1000 Units/Reel
SL(T4)	Surface Mount (Low Profile) Lead Forming – With Option 4 Taping	1000 Units/Reel
SLM(T1)	Surface Mount (Gullwing) Lead Forming– With Option 1 Taping	1500 Units/Reel
SLM(T2)	Surface Mount (Gullwing) Lead Forming – With Option 2 Taping	1500 Units/Reel



**Carrier Tape Specifications** *Dimensions in mm unless otherwise stated*

**Option S(T1) & SL(T1)**

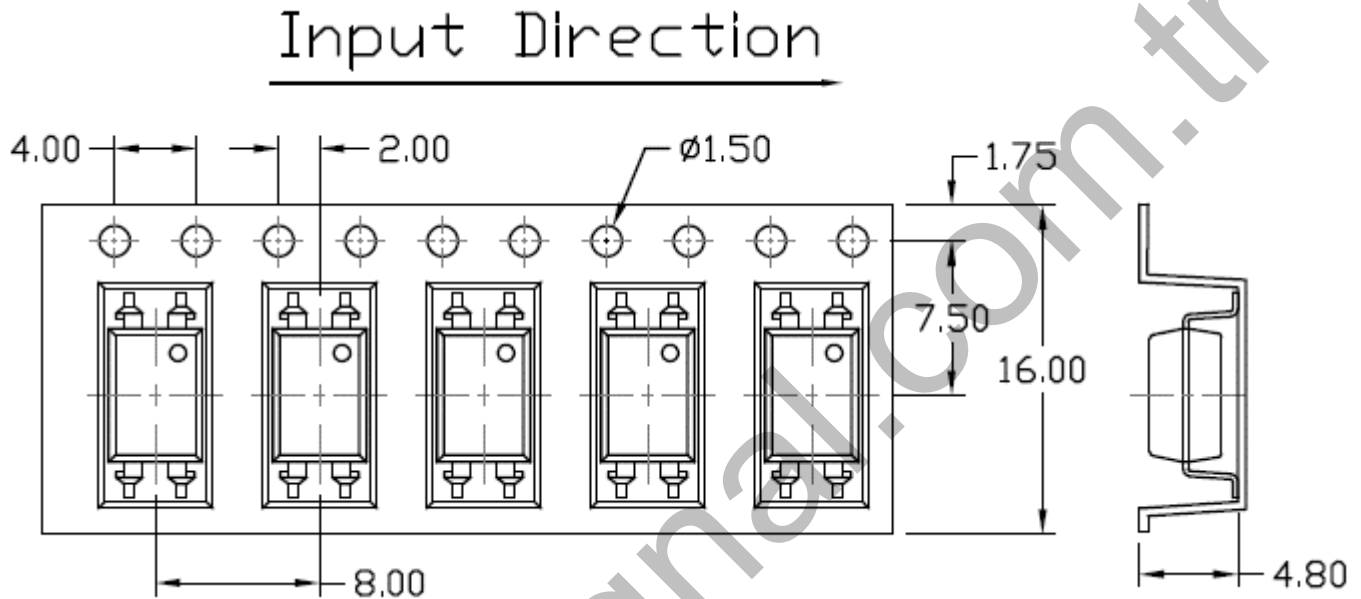

**Option S(T2) & SL(T2)**

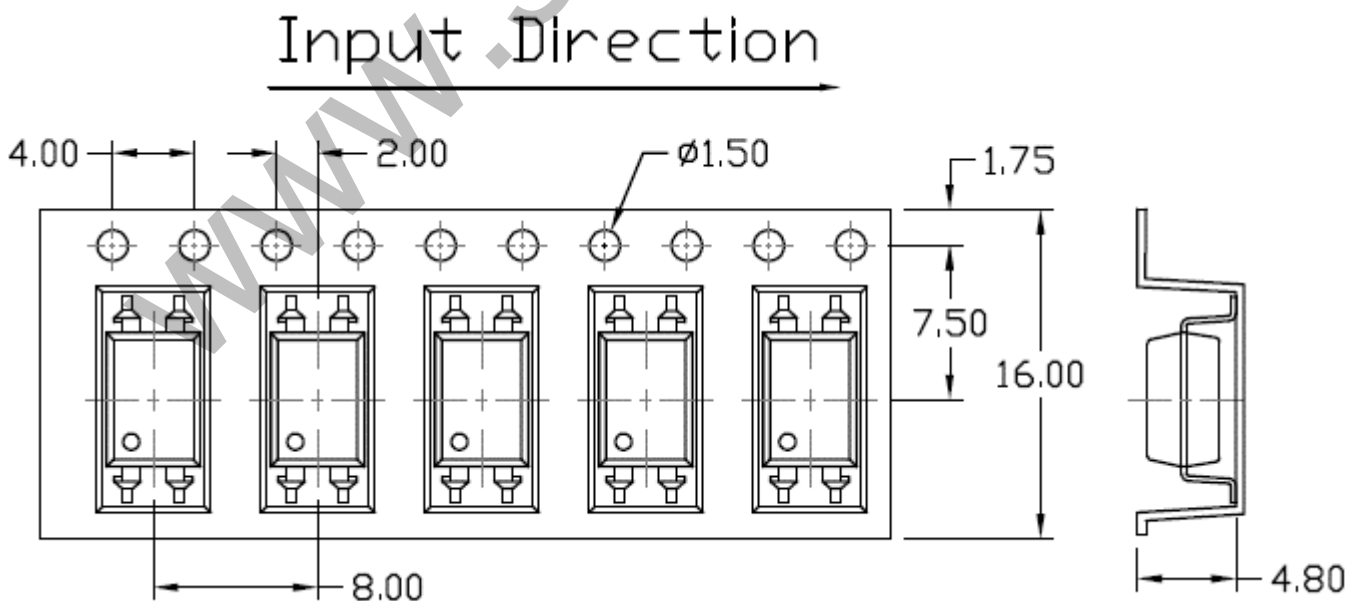



Option S(T3) & SL(T3)

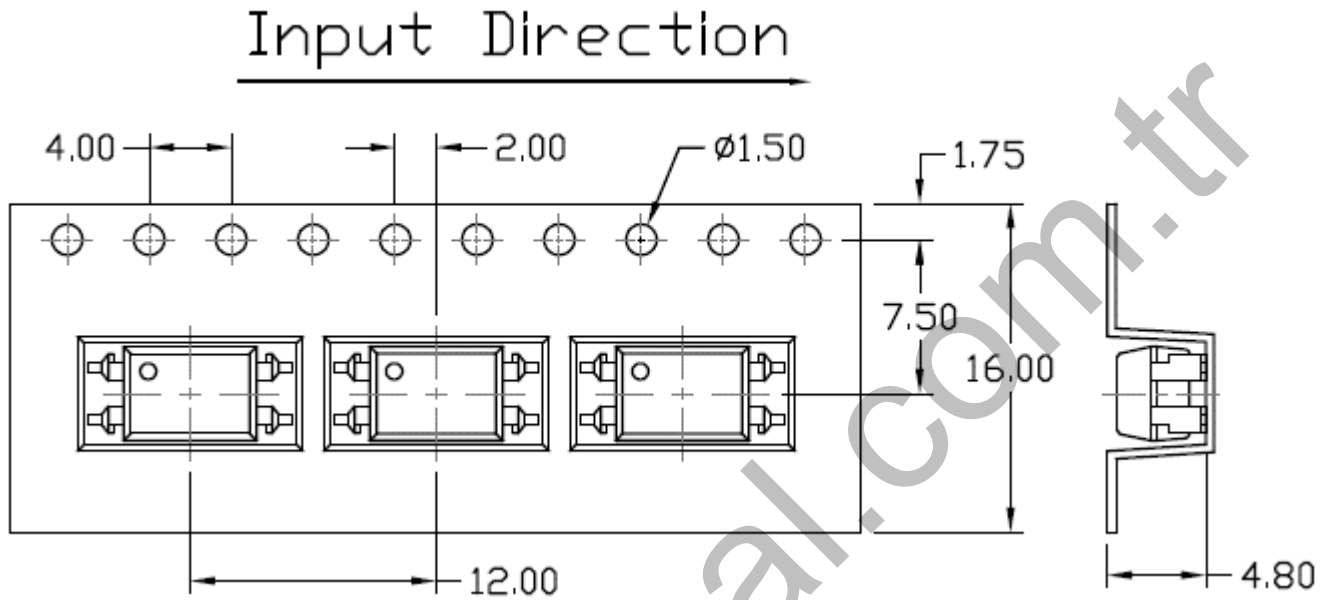

Option S(T4) & SL(T4)

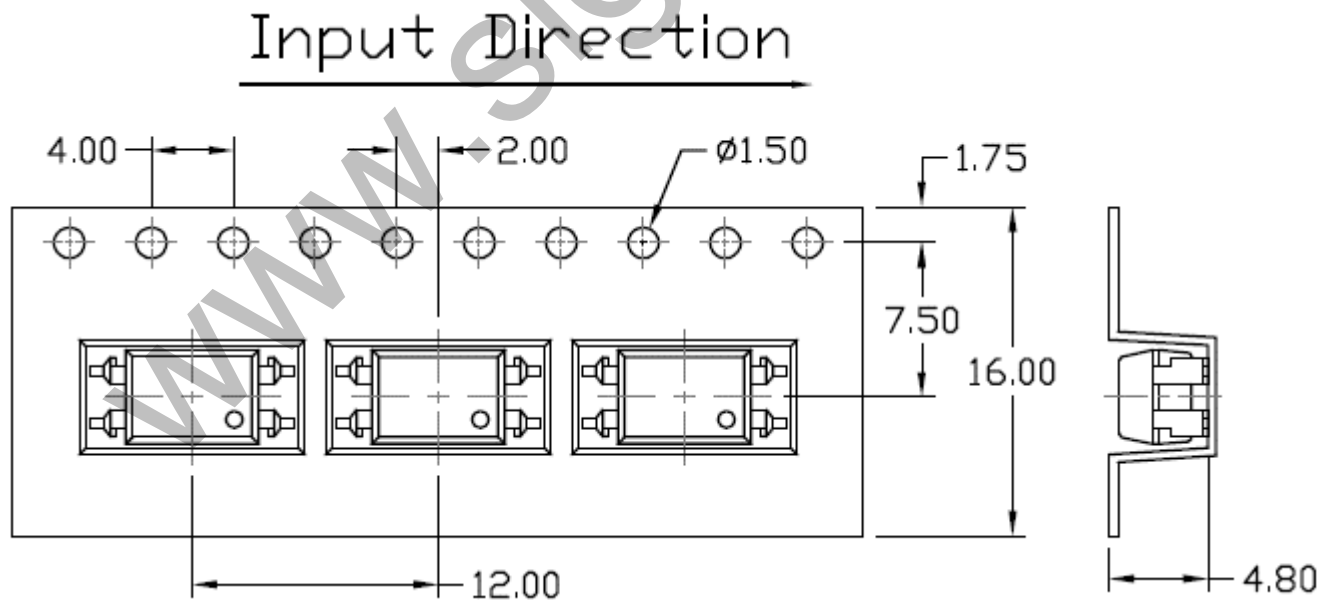



Option SLM(T1)

Input Direction

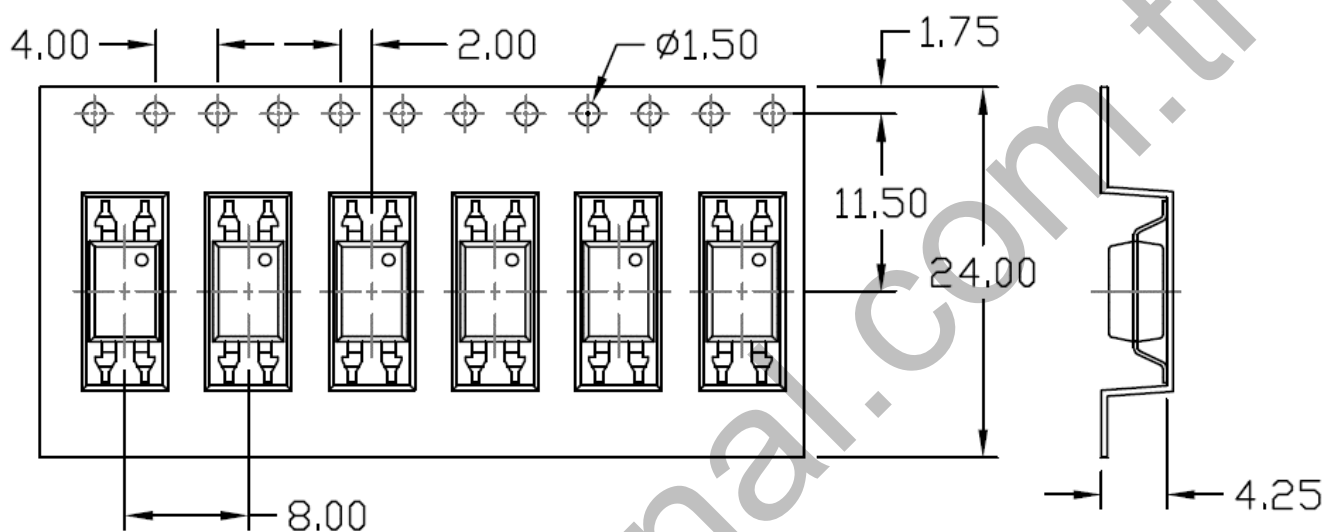

Option SLM(T2)

Input Direction

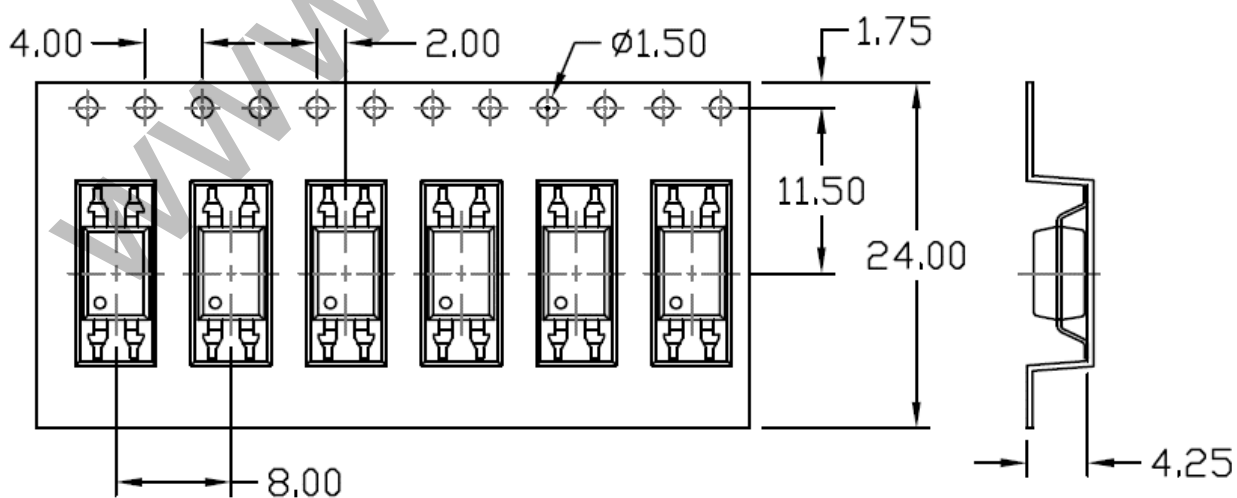



**Wave soldering (follow the JEDEC standard JESD22-A111)**

One time soldering is recommended within the condition of temperature.

Temperature:  $260 \pm 5^\circ\text{C}$ .

Time: 10 sec.

Preheat temperature: 25 to  $140^\circ\text{C}$ .

Preheat time: 30 to 80 sec.

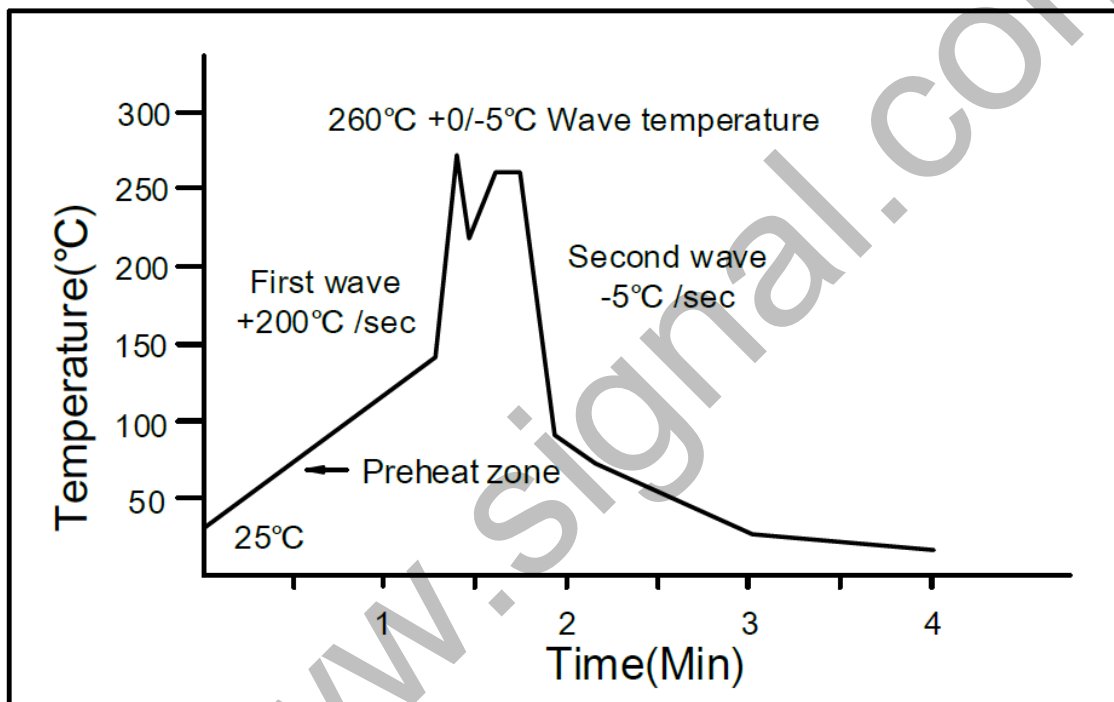

**Iron soldering (follow the standard MIL-STD 202G, Method 210F)**

Allow single lead soldering in every single process.

One time soldering is recommended. Temperature:  $350 \pm 10^\circ\text{C}$

Time: 5 sec max.



### Reflow Profile

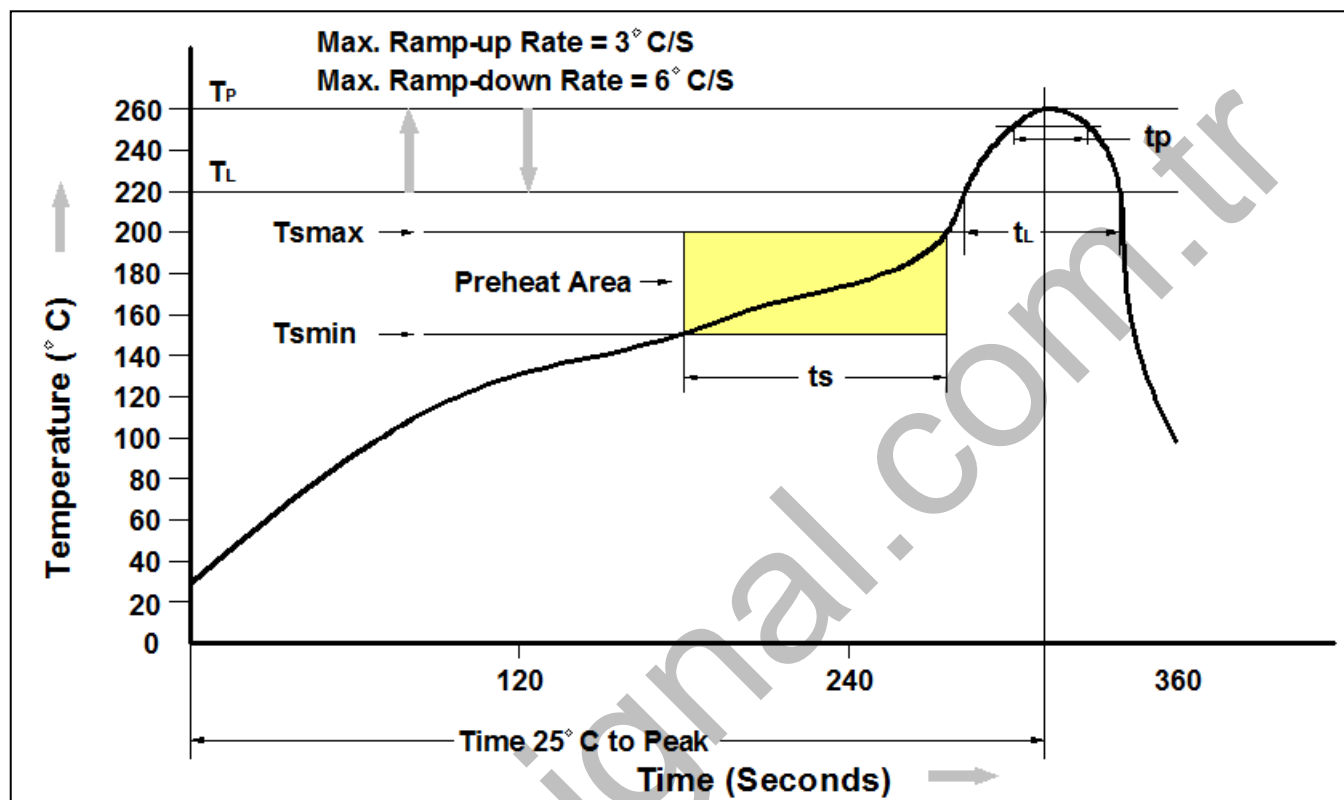

Profile Feature	Pb-Free Assembly Profile
Temperature Min. (Tsmin)	150°C
Temperature Max. (Tsmax)	200°C
Time (ts) from (Tsmin to Tsmax)	60-120 seconds
Ramp-up Rate (tl to tp)	3°C/second max.
Liquidous Temperature (Tl)	217°C
Time (tl) Maintained Above (Tl)	60 – 150 seconds
Peak Body Package Temperature	260°C +0°C / -5°C
Time (tp) within 5°C of 260°C	30 seconds
Ramp-down Rate (Tp to Tl)	6°C/second max
Time 25°C to Peak Temperature	8 minutes max.



---

## DISCLAIMER

CT MICRO RESERVES THE RIGHT TO MAKE CHANGES WITHOUT FURTHER NOTICE TO ANY PRODUCTS HEREIN TO IMPROVE RELIABILITY, FUNCTION OR DESIGN. CT MICRO DOES NOT ASSUME ANY LIABILITY ARISING OUT OF THE APPLICATION OR USE OF ANY PRODUCT OR CIRCUIT DESCRIBED HEREIN; NEITHER DOES IT CONVEY ANY LICENSE UNDER ITS PATENT RIGHTS, NOR THE RIGHTS OF OTHERS.

---

DISCOLORATION MIGHT OCCUR ON THE PACKAGE SURFACE AFTER SOLDERING, REFLOW OR LONG TERM USE. THIS DOES NOT IMPACT THE PRODUCT PERFORMANCE NOR THE PRODUCT RELIABILITY.

---

CT MICRO ARE NOT AUTHORIZED FOR USE AS CRITICAL COMPONENTS IN LIFE SUPPORT DEVICES OR SYSTEMS WITHOUT EXPRESS WRITTEN APPROVAL OF CT MICRO INTERNATIONAL CORPORATION.

- 1. Life support devices or systems are devices or systems which, (a) are intended for surgical implant into the body, or (b) support or sustain life, or (c) whose failure to perform when properly used in accordance with instruction for use provided in the labelling, can be reasonably expected to result in significant injury to the user.*
- 2. A critical component is any component of a life support device or system whose failure to perform can be reasonably expected to cause the failure of the life support device or system, or to affect its safety or effectiveness.*